



LEGNI HIGH-TECH

**ARIOSTEA**<sup>®</sup> LEGNI HIGH-TECH



#### CREDITS

art direction: Marco Porpora, Marketing Ariostea  
imaging 3D: Riccardo Urnato Fotografo, Fotomodo  
photo: mamaphoto.it  
graphic project: up-comunicazione.com

printed in Italy - September 2013  
edition: n.2 - 2013

Ariostea all right reserved



I Legni High-Tech sono l'esaltazione della tecnologia. Riproducono in modo incredibilmente fedele l'aspetto, le sensazioni tattili, le venature del parquet. Per avvicinarsi così alla perfezione, non è stata toccata nemmeno una foglia. La tecnologia produttiva dei Legni High-Tech garantisce ai listoni una resistenza a carichi di rottura eccezionalmente elevata. Questo vuol dire non subire flessioni, non alterare la linearità, non spostarsi di un millimetro, mai. L'impatto visivo è quello del parquet, ma la forza è quella della pietra. Il rigore estetico del design a listoni dei grandi parquet si abbina senza rinunce alle esigenze di resistenza al peso e al carico degli ambienti contemporanei. Sui Legni High-Tech non si vedono i segni del tempo. Compattezza, omogeneità e struttura uniforme li rendono incredibilmente resistenti alle abrasioni più profonde, alle aggressioni chimiche e a quelle di un calpestio infinito nel tempo. I nostri listoni sono unici. Toccare per credere. Questo è il miglior modo per cogliere l'unicità di questi materiali. Ci si ritrova la struttura e il calore del parquet, ma a questa vocazione Ariostea ha aggiunto caratteristiche tecniche che li rendono superiori.

Legni High-Tech are technology taken to its highest level. They reproduce all the appearance, tactile sensations and veins of natural wood, down to the tiniest detail. Yet all this perfection is achieved without harming a single leaf. The production technology of Legni High-Tech slabs guarantees exceptionally high breaking strength. And this means no bending, absolute maintenance of linearity, and no shifting, even by a millimetre. Ever. The visual impact may be that of wood, but they are as strong as stone. And the immaculate “parquet block” floor they create will happily provide all the weight and load resistance required in contemporary installation contexts. On Legni High-Tech, the signs of time are invisible. Compact, homogeneous and with a uniform structure, they are incredibly resistant to the deepest abrasion, chemical attack and infinite traffic over time. Our slabs are unique. You have to touch this material with your own hands to appreciate its unique qualities. It has all the texture and warmth of wood, but Ariosteas has combined this vocation with technical characteristics that make them superior.

Die Legni High-Tech sind die Apotheose der Technik. Sie geben die Optik, die Haptik und die Äderungen des Holzes mit verblüffender Naturtreue wieder. Um ein derartiges Maß an Vollkommenheit zu erreichen, wurde kein einziges Zweiglein berührt. Die Herstellungstechnik der Legni High-Tech gewährleistet den Dielen eine außerordentlich hohe Bruchlastbeständigkeit. Damit entstehen keine Verbiegungen, wird die Geradlinigkeit nicht beeinträchtigt und gibt das Material auch keinen einzigen Millimeter nach. Niemals. Die Optik des Holzes und die Kraft des Steins. Die optische Strenge des Dielenmusters von Parkettböden vereint sich kompromisslos mit den Gewichts- und Lastbeständigkeitsanforderungen der modernen Architektur. Auf den Legni High-Tech hinterlässt die Zeit keine Spuren. Kompaktheit, Homogenität und ebene Struktur machen sie unglaublich widerstandsfähig gegenüber Tiefenabrieb, Chemikalien und Trittbeanspruchungen. Unsere Dielen sind einzigartig. Wenn Sie Ihren Augen nicht trauen, dann lassen Sie doch einfach die Hand über die Oberflächen gleiten. Damit erkennen Sie am besten die Einzigartigkeit dieser Materialien.









Les Legni High - Tech sont l'exaltation de la technologie. Ils reproduisent avec une incroyable fidélité l'aspect, les perceptions tactiles, les veinures du bois naturel. Et pour atteindre une telle perfection, nous n'avons même pas touché une feuille. La technologie de production des Legni High - Tech permet de garantir une très grande résistance des lamelles à la rupture; c'est-à-dire qu'elles ne subissent aucun fléchissement, que leur alignement n'est pas altéré, qu'elles ne bougent pas d'un millimètre. En aucun cas. Visuellement elles ont l'aspect du bois, mais elles gardent la force de la pierre. La rigueur esthétique du design des grands parquets à lamelles est assortie, sans contraintes, aux exigences de résistance au poids et à la charge des environnements contemporains. L'usure du temps n'apparaît jamais sur les Legni High-Tech. Du fait de leur compacité, de leur homogénéité et de leur structure uniforme, ils sont extrêmement résistants aux abrasions les plus profondes, aux agressions chimiques et au piétinement. Une résistance infinie dans le temps. Nos lames sont uniques. Il faut les toucher pour y croire. C'est la meilleure façon d'appréhender le caractère unique de ces matériaux. On y retrouve la structure et la chaleur du bois ; mais Arioste a ajouté des particularités techniques à cette vocation naturelle.

Коллекция Legni High Tech компании Ариостеа это превосходство технологий, которые максимально достоверно воспроизводят тактильные ощущения паркета. Настолько приблизившись к совершенству, мы не уничтожили ни одного живого дерева. Производственная технология Legni High Tech гарантирует «керамическим» планкам невероятно высокую степень сопротивления нагрузкам. Это означает: сопротивление на изгиб, не изменяемая прямолинейность, сохранение линейных размеров. Визуальный эффект паркета, но сила камня. Реалистичность дизайна планок больших паркетов сочетается с возможностью сопротивляться нагрузкам современной среды. На материале Legni High Tech не видны следы времени. Плотность и однородная структура делают их невероятно стойкими к абразивному, химическому воздействию и высокому трафику. Наши паркетные планки реалистичны. Прикоснитесь, чтобы поверить. Только так можно понять уникальность этого материала. В нем вы найдете структуру и тепло настоящего дерева. Компания Ариостеа добавила к этому еще и технические свойства, которые делают этот материал превосходящим свойства натурального паркета.







rovere 120



rovere tundra





Floor: rovere tundra  
120x30, 120x20, 120x15



Floor: rovere tundra  
120x30, 120x20, 120x15

A photograph of a wooden floor with a brick wall on the right and a bright window in the background. The floor is made of wide, light-colored wooden planks with a natural grain. The brick wall is made of light-colored bricks with a textured surface. The background is a bright, overexposed window or doorway, creating a strong contrast with the interior.

rovere provenzale





Floor: rovere provenzale  
120x20, 120x15





Floor: rovere provenzale  
120x20, 120x15



rovere cenere





Rovere cenere  
120x30, 120x20, 120x15



Rovere cenere  
120x30, 120x20, 120x15



rovere sabbia





Floor: rovere sabbia  
120x30, 120x20, 120x15





Floor: rovere sabbia  
120x30, 120x20, 120x15

The image features a background of light-colored wooden planks with a visible grain pattern, arranged in a staggered fashion. A solid, muted green vertical bar runs along the left edge of the image. In the bottom-left corner, the text "rovere corda" is written in a clean, white, lowercase sans-serif font.

rovere corda





Floor: rovere corda  
120x20, 120x15



Floor: rovere corda  
120x20, 120x15

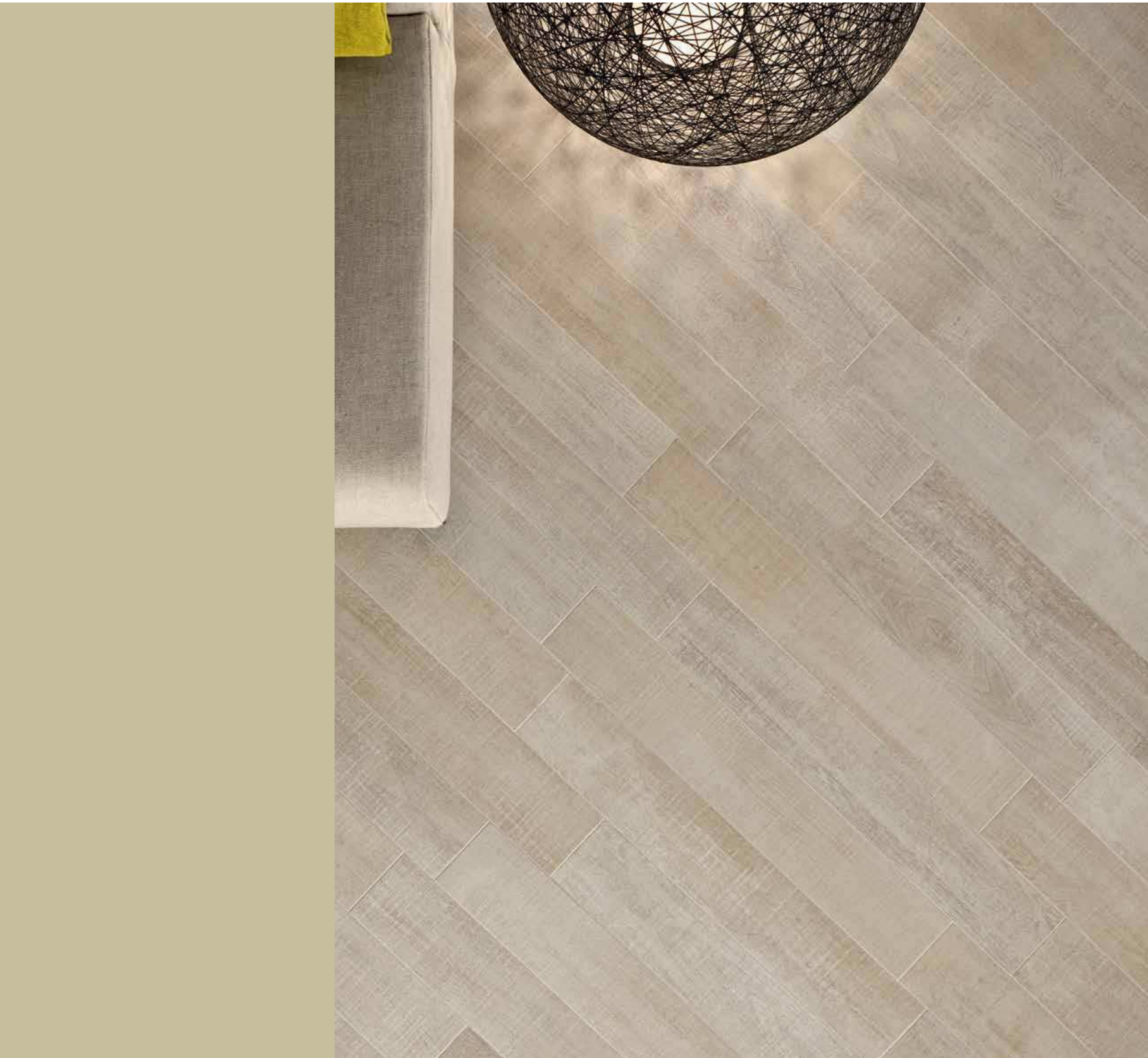

Floor: rovere corda  
120x15



rovere decapè





Floor: rovere decapè  
120x30, 120x20, 120x15





Floor: rovere decapè  
120x30, 120x20, 120x15



rovere briccola





Floor: rovere briccola  
120x30, 120x20, 120x15



Floor: rovere briccola  
120x20, 120x15





rovere noce



Floor: rovere noce  
120x30, 120x20, 120x15





Floor: rovere noce  
120x30, 120x20, 120x15



rovere country





Floor: rovere country  
120x30, 120x20, 120x15



Floor: rovere country  
120x30, 120x20, 120x15



rovere impero





Floor: rovere impero  
120x20, 120x15



Floor: rovere impero  
120x20, 120x15





Floor: rovere impero  
120x20, 120x15





rovere reale



Floor: rovere reale  
120x30, 120x20, 120x15



Floor: rovere reale  
120x30, 120x20, 120x15





rovere moka



Floor: rovere moka  
120x15





Floor: rovere moka  
120x30, 120x20, 120x15



Floor: rovere moka  
120x15



rovere scuro



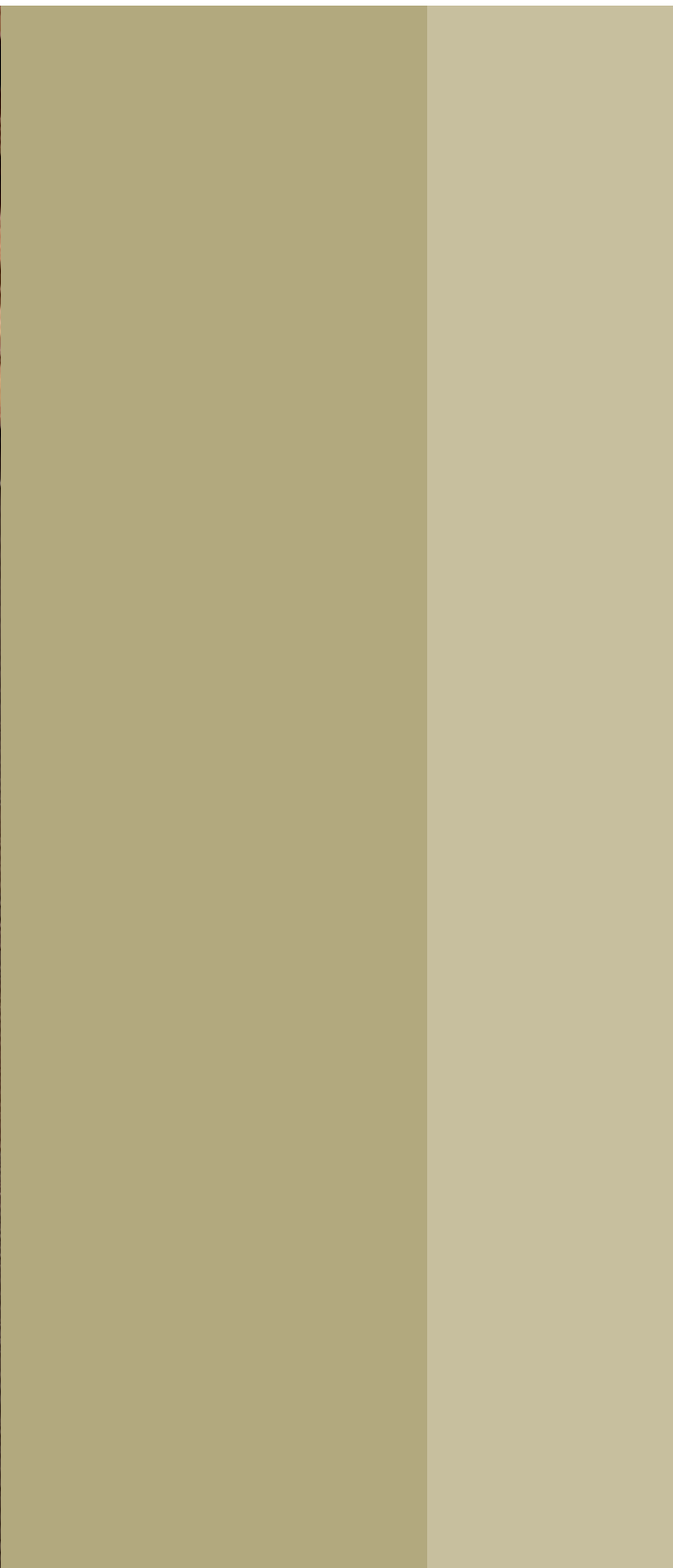

Floor: rovere scuro  
120x30, 120x20, 120x15



Floor: rovere scuro  
120x20, 120x15





rovere moro



Floor: rovere moro  
120x30, 120x20, 120x15





Floor: rovere mora  
120x30, 120x20, 120x15





rovere 90

rovere grigio





Floor: rovere grigio  
90x22,5, 90x15, 90x11



Floor: rovere grigio  
90x11







rovere bianco



Floor: rovere bianco  
90x11





rovere chiaro





Floor: rovere chiaro  
90x11



Floor: rovere chiaro  
90x11



rovere naturale







Floor: rovere naturale  
90x22,5, 90x15, 90x11



Floor: rovere naturale  
90x22,5, 90x15, 90x11





rovere biondo



Floor: rovere biondo  
90x15

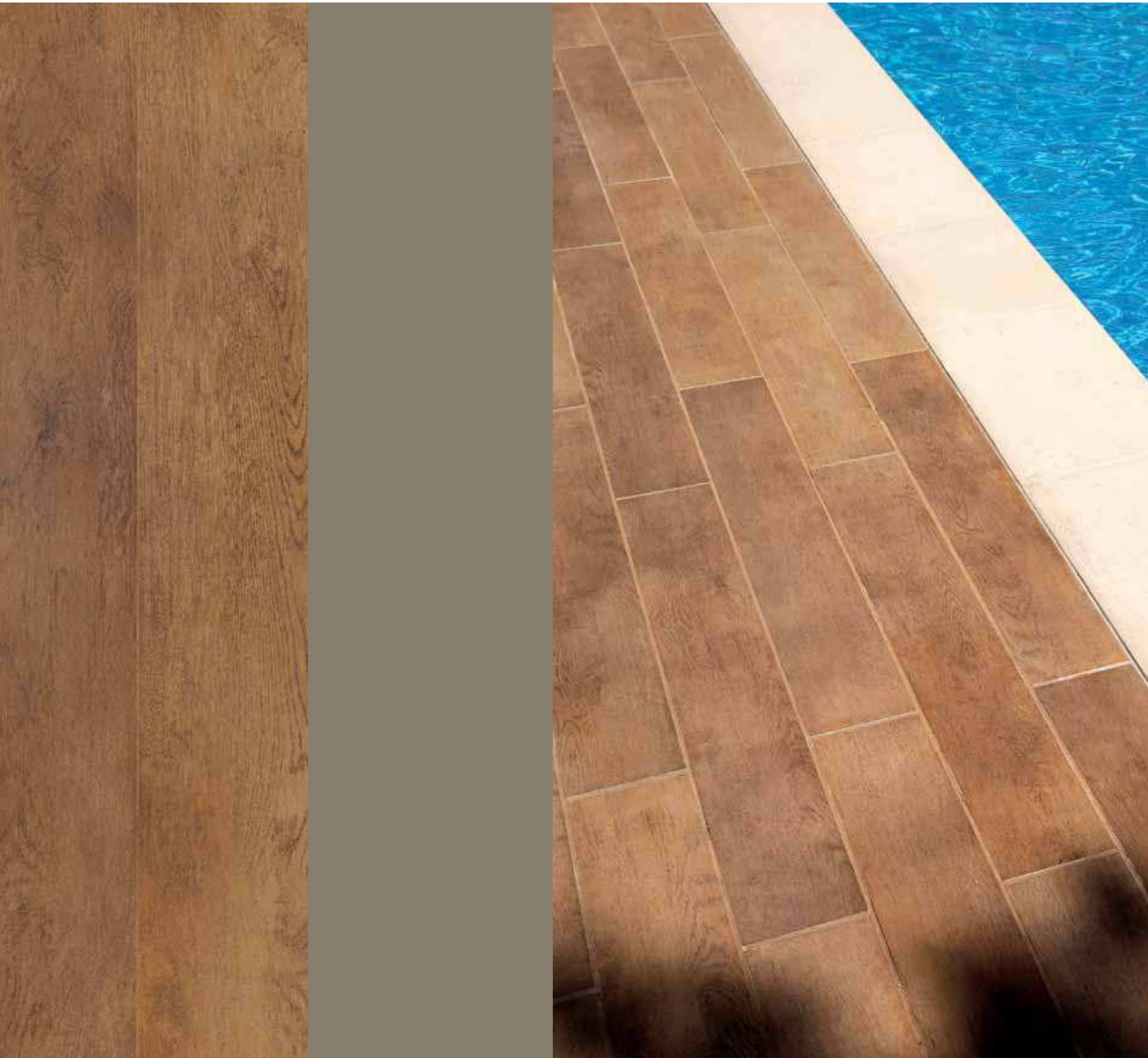

Floor: rovere biondo  
90x15







rovere ciliegio



Floor: rovere ciliegio  
90x11



Rovere ciliegio  
90x22,5, 90x15, 90x11



rovere antico





Floor: rovere antico  
90x11



Floor: rovere antico  
90x15



Floor: rovere antico  
90x22,5







rovere abbazia



Floor: rovere abbazia  
90x22,5, 90x15, 90x11



Floor: rovere abbazia  
90x22,5, 90x15, 90x11

rovere nero





Floor: rovere nero  
90x15



Floor: rovere nero  
90x15



Floor: rovere nero  
90x15, 90x11

# formati

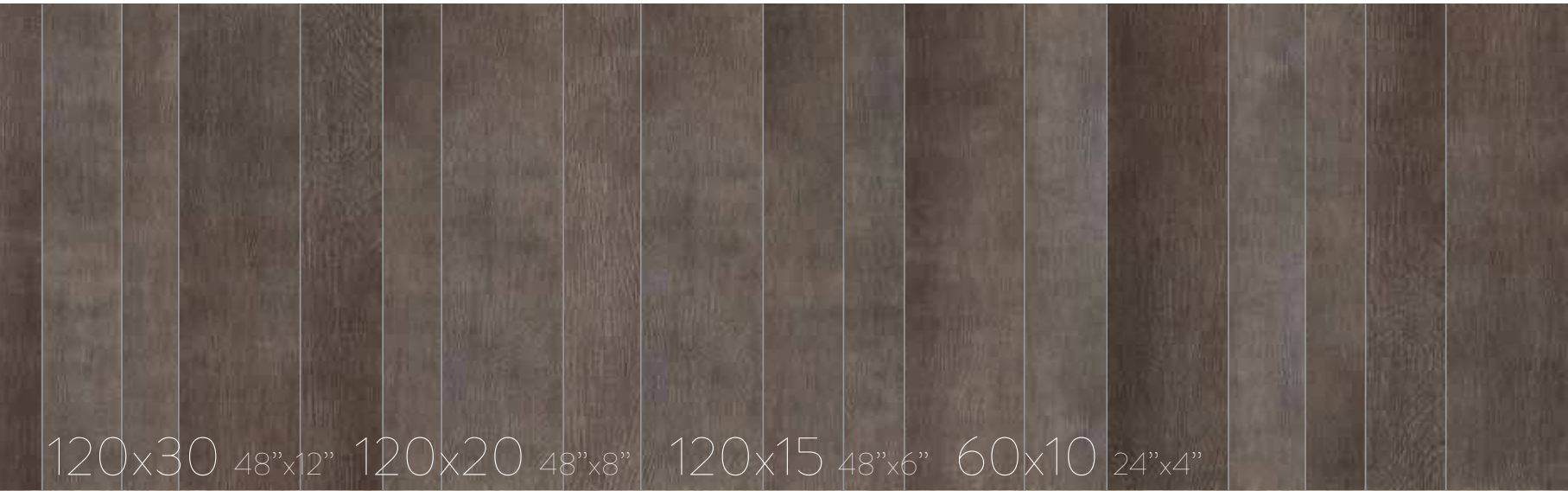
A horizontal row of dark brown wood plank samples. The planks are arranged in four groups, each representing a different size. The first group has three planks, the second has two, the third has two, and the fourth has one. The planks have a vertical grain and a slightly textured surface.

120x30 48"x12" 120x20 48"x8" 120x15 48"x6" 60x10 24"x4"

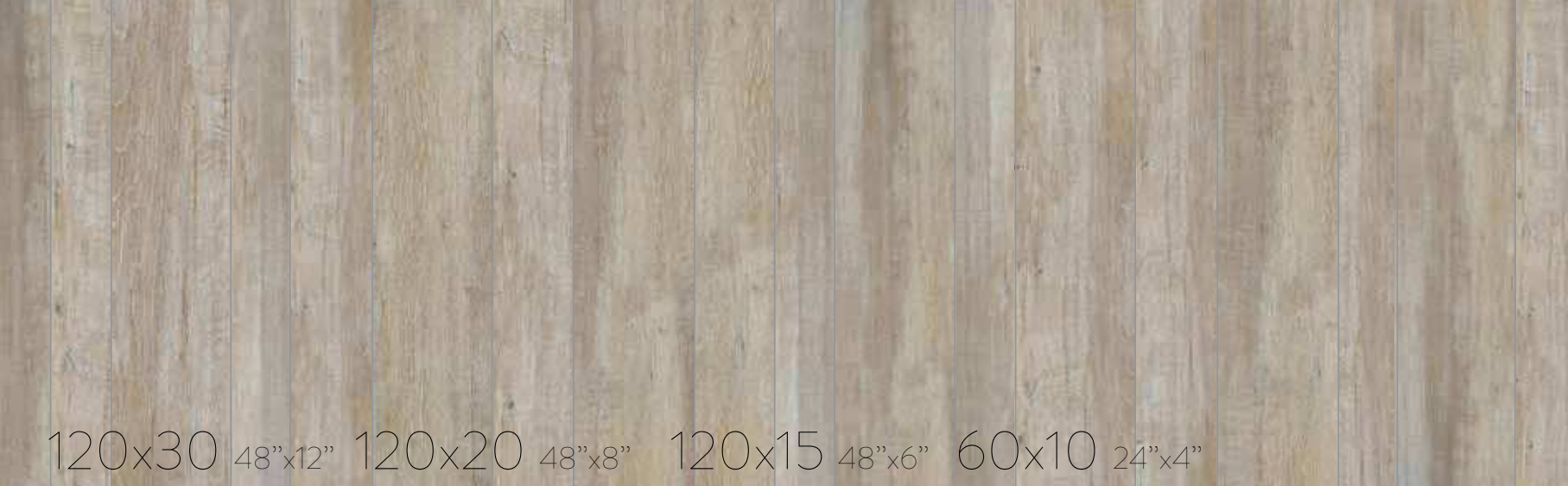
A horizontal row of light-colored wood plank samples, similar in arrangement to the dark wood row above. The planks are arranged in four groups: three, two, two, and one plank per group. The wood has a vertical grain and a more natural, slightly weathered appearance.

120x30 48"x12" 120x20 48"x8" 120x15 48"x6" 60x10 24"x4"



sizes formate formats форматы

A (R10) 10mm

New

A+B (R10) 10mm

ROVERE  
TUNDRA

ROVERE  
PROVENZALE

A close-up view of a light-colored wood plank texture with vertical grain and subtle variations in tone.

120x30 48"x12" 120x20 48"x8" 120x15 48"x6" 60x10 24"x4"

A close-up view of a light-colored wood plank texture, similar to the first image but with slightly different lighting and grain patterns.

120x30 48"x12" 120x20 48"x8" 120x15 48"x6" 60x10 24"x4"

A close-up view of a light-colored wood plank texture, showing more pronounced vertical grain and some darker spots.

120x30 48"x12" 120x20 48"x8" 120x15 48"x6" 60x10 24"x4"

A close-up view of a darker, more saturated wood plank texture with prominent vertical grain and natural wood imperfections.

120x30 48"x12" 120x20 48"x8" 120x15 48"x6" 60x10 24"x4"

A+B (R10) 10mm

ROVERE  
CENERE

A+B (R10) 10mm

ROVERE  
SABBIA

A (R10) 10mm | ACTIVE

ROVERE  
CORDA

A (R10) 10mm

ROVERE  
DECAPÉ

A close-up view of light-colored wood planks with a subtle grain pattern. The planks are arranged vertically and separated by thin blue lines.

120x30 48"x12" 120x20 48"x8" 120x15 48"x6" 60x10 24"x4"

A close-up view of light-colored wood planks with a subtle grain pattern. The planks are arranged vertically and separated by thin blue lines.

120x30 48"x12" 120x20 48"x8" 120x15 48"x6" 60x10 24"x4"

A close-up view of medium-colored wood planks with a more pronounced grain pattern. The planks are arranged vertically and separated by thin blue lines.

120x30 48"x12" 120x20 48"x8" 120x15 48"x6" 60x10 24"x4"

A close-up view of dark-colored wood planks with a very pronounced grain pattern. The planks are arranged vertically and separated by thin blue lines.

120x30 48"x12" 120x20 48"x8" 120x15 48"x6" 60x10 24"x4"

New

ROVERE  
BRICCOLA

A+B (R11)  $\frac{10\text{mm}}{\triangle}$

ROVERE  
NOCE

A+B (R10)  $\frac{10\text{mm}}{\triangle}$

New

ROVERE  
COUNTRY

A (R10)  $\frac{10\text{mm}}{\triangle}$

ROVERE  
IMPERO

A (R10)  $\frac{10\text{mm}}{\triangle}$

120x30 48"x12" 120x20 48"x8" 120x15 48"x6" 60x10 24"x4"

120x30 48"x12" 120x20 48"x8" 120x15 48"x6" 60x10 24"x4"

120x30 48"x12" 120x20 48"x8" 120x15 48"x6" 60x10 24"x4"

120x30 48"x12" 120x20 48"x8" 120x15 48"x6" 60x10 24"x4"

A (R10)  $\frac{10\text{mm}}{\triangle}$

New

A+B (R11)  $\frac{10\text{mm}}{\triangle}$  | ACTIVE

A+B (R11)  $\frac{10\text{mm}}{\triangle}$

A+B (R10)  $\frac{10\text{mm}}{\triangle}$

ROVERE  
REALE

ROVERE  
MOKA

ROVERE  
SCURO

ROVERE  
MORO

90x22,5 36"x9" 90x15 36"x6" 90x11 36"x4<sup>1/2</sup>"

90x22,5 36"x9" 90x15 36"x6" 90x11 36"x4<sup>1/2</sup>"

90x22,5 36"x9" 90x15 36"x6" 90x11 36"x4<sup>1/2</sup>"

90x22,5 36"x9" 90x15 36"x6" 90x11 36"x4<sup>1/2</sup>"

90x22,5 36"x9" 90x15 36"x6" 90x11 36"x4<sup>1/2</sup>"





ROVERE  
GRIGIO

A+B+C (R11) 10mm ACTIVE



ROVERE  
BIANCO

A+B+C (R10) 10mm ACTIVE



ROVERE  
CHIARO

A+B+C (R10) 10mm



ROVERE  
NATURALE

A+B (R10) 10mm ACTIVE



ROVERE  
BIONDO

A+B+C (R9) 10mm ACTIVE

90x22,5 36"x9" 90x15 36"x6" 90x11 36"x4 1/2"

90x22,5 36"x9" 90x15 36"x6" 90x11 36"x4 1/2"

90x22,5 36"x9" 90x15 36"x6" 90x11 36"x4 1/2"

90x22,5 36"x9" 90x15 36"x6" 90x11 36"x4 1/2"

90x22,5 36"x9" 90x15 36"x6" 90x11 36"x4 1/2"

A+B (R10)  $\frac{10\text{mm}}{\triangle}$

A+B (R11)  $\frac{10\text{mm}}{\triangle}$  | ACTIVE

A+B (R10)  $\frac{10\text{mm}}{\triangle}$

A (R10)  $\frac{10\text{mm}}{\triangle}$

A+B+C (R11)  $\frac{10\text{mm}}{\triangle}$

ROVERE  
CILIEGIO

ROVERE  
MOKA

ROVERE  
ANTICO

ROVERE  
ABBAZIA

ROVERE  
NERO

**DESCRIZIONE** Active Clean Air & Antibacterial Ceramic™ è una nuova finitura ottenuta attraverso una metodologia basata su un trattamento innovativo al biossido di titanio in forma micrometrica, che agisce da fotocatalizzatore, effettuato sulle lastre in gres porcellanato a temperatura elevata.

**PROPRIETA'** L'applicazione di Active Clean Air & Antibacterial Ceramic™ concretizza le tre qualità del materiale, attivando tre azioni molto importanti che sono: antinquinante, antibatterica, autopulente (solo per pareti esterne).

**UTILIZZO** Le eccellenti qualità fisico chimiche di Active Clean Air & Antibacterial Ceramic™ lo rendono ideale per i seguenti impieghi: rivestimenti esterni di edifici, rivestimenti interni, rivestimenti nel settore: ospedaliero e sanitario, scolastico, wellness, ambiti in cui l'igiene è requisito indispensabile.

**VANTAGGI** In presenza di luce e aria si attiva un forte processo ossidativo che porta alla decomposizione di determinate sostanze organiche ed inorganiche quando queste vengano a contatto con la superficie di Active Clean Air & Antibacterial Ceramic™. I vantaggi che si possono trarre dall'utilizzo di Active sono: mantenimento e conservazione delle caratteristiche estetiche e, al contempo, la possibilità di avere superfici che repellono lo sporco, abbattimento di diversi inquinanti, purificazione dell'aria, eliminazione di batteri.

# ACTIVE™

CLEAN AIR & ANTIBACTERIAL CERAMIC

**BESCHREIBUNG** Active Clean Air & Antibacterial Ceramic™ ist eine neue Ausführung, die auf einer innovativen Behandlung mit als Fotokatalysator wirkendem Titanbioxyd in mikrometrischer Form basiert. Die Behandlung der Feinsteinzeugplatten erfolgt bei hoher Temperatur.

**EIGENSCHAFTEN** Die Anwendung von Active Clean Air & Antibacterial Ceramic™ konkretisiert die drei Qualitäten des Materials durch: umweltschützende Wirkung, antibakterielle Wirkung, selbstreinigende Wirkung (nur für Aussenfassaden).

**VERWENDUNG** Durch die vortrefflichen physikalisch-chemischen Eigenschaften von Active Clean Air & Antibacterial Ceramic™ eignet sich dieses Produkt vortrefflich für den Einsatz in den folgenden Bereichen: Außenverkleidungen von Gebäuden, Innenverkleidungen, Verkleidungen auf folgenden Gebieten: Spitäler/ Krankenhäuser und Sanitär, Schulen, Wellness, Umgebungen, in denen Hygiene absolut erforderlich ist.

**VORTEILE** Unter der Einwirkung von Licht tritt ein intensiver Oxydationsprozess ein, der zur Zersetzung gewisser organischer und nicht organischer Stoffe führt, wenn diese mit der Oberfläche des Active Clean Air & Antibacterial Ceramic™ in Berührung kommen. Die Verwendung von Active bringt folgende Vorteile: Aufrechterhaltung unveränderter ästhetischer Eigenschaften und gleichzeitig die Möglichkeit, über schmutzabstossende Oberflächen zu verfügen, Vernichtung verschiedener Schadstoffe, Reinigung der Luft, Beseitigung der Bakterien.

**DESCRIPTION** Active Clean Air & Antibacterial Ceramic™ is a new finish obtained through a production methodology based on an innovative micrometric titanium dioxide process, which acts as a photocatalyst, carried on porcelain slabs at high temperature.

**PROPERTIES** Applying Active Clean Air & Antibacterial Ceramic™ brings out the three qualities of the material, activating three very important actions that are: anti-pollution, antibacterial, self-cleaning (only for external walls).

**USE** The excellent physical-chemical characteristics of Active Clean Air & Antibacterial Ceramic™ make it ideal for the following applications: exterior cladding of buildings, interior, walls in following areas: Hospitals and health centres, Schools, Wellness centres, Environments where hygiene is an essential requirement.

**ADVANTAGES** In presence of light and air, a strong oxidation is activated by Active Clean Air & Antibacterial Ceramic™, that leads to the decomposition of particular organic and inorganic substances, when they come into contact with the surface of Active. The benefits achieved with the use of Active are: maintenance and preservation of aesthetic characteristics and, meanwhile, the possibility to have surfaces repelling dirt, abatement of different pollutants, air purification, elimination of bacteria.



**DESCRIPTION** Active Clean Air & Antibacterial Ceramic™ es une nouvelle finition. La technique de fabrication s'appuie sur un traitement révolutionnaire qui utilise le dioxyde de titane à l'échelle micrométrique – le photocatalyseur – sur les dalles en grès cérame, à hautes températures.

**PROPRIÉTÉS** Active Clean Air & Antibacterial Ceramic™ apporte les trois qualités matérielles via trois actions très importantes: antipolluante, antibactérienne, autonettoyante (seulement pour murs extérieurs).

**APPLICATION** Grâce à ses extraordinaires qualités physicochimiques, Active Clean Air & Antibacterial Ceramic™ est recommandé pour les applications suivantes: revêtement des façades, revêtements intérieurs, revêtements dans le secteur: hospitalier et sanitaire, éducation nationale, wellness, lieux où l'hygiène est un critère indispensable.

**AVANTAGES** L'action combinée de la lumière et de l'air déclenche une oxydation intense qui entraîne le décomposition de certaines substances organiques et inorganiques, lorsqu'elles entrent en contact avec la surface Active Clean Air & Antibacterial Ceramic™. Les avantages d'Active sont: maintien et conservation des caractéristiques esthétiques et, en même temps, possibilité d'avoir des surfaces autonettoyantes, réduction de plusieurs polluants, purification de l'air, suppression des bactéries.



BE ACTIVE

BE a TREE!

**ОПИСАНИЕ** Active Clean Air & Antibacterial Ceramic™ – это новый облицовочный материал, полученный благодаря технологии, которая основана на применении микрочастиц диоксида титана, наносимых на керамическую плитку при высокой температуре и действующих как фотокатализатор.

**СВОЙСТВА.** Active Clean Air & Antibacterial Ceramic™ обладает тремя важными свойствами: на его поверхности не удерживаются загрязнения, он оказывает антибактериальное действие и имеет способность самоочистки (только при использовании для наружных стен).

**ПРИМЕНЕНИЕ.** Благодаря своим исключительным физико-химическим свойствам Active Clean Air & Antibacterial Ceramic™ идеально подходит для наружной и внутренней отделки зданий, а также для облицовки стен внутри больниц, поликлиник, школ, спортивных клубов и прочих помещений, для которых гигиена особенно важна.

**ПРЕИМУЩЕСТВА.** Наличие света и воздушной среды провоцирует мощный окислительный процесс, в результате которого разлагаются определенные органические и неорганические вещества при их контакте с поверхностью Active Clean Air & Antibacterial Ceramic™. Преимущества от применения этого материала заключаются в том, что грязеотталкивающий и бактерицидный эффекты, а также защита от загрязняющих веществ и поддержание чистоты воздуха становятся возможными без ущерба для эстетических характеристик отделки.

[www.active-ceramic.com](http://www.active-ceramic.com)

Il trattamento ACTIVE può indurre variazioni cromatiche e di brillantezza sui materiali, più sensibili sui colori scuri.

ACTIVE treatment can induce variations of colours and brightness on the material, more noticeable on dark colours.

Die ACTIVE Behandlung kann Farb- und Glanzabweichungen auf den Materialien zur Folge haben. Bei dunklen Farben sind diese leichter bemerkbar.

Le traitement ACTIVE peut induire de variations de couleur et de luminosité sur les matériaux, le plus sensible sur les couleurs foncées.

Покрытие Active Clean Air & Antibacterial Ceramic™ может придавать различные оттенки и блеск материалам, особенно заметным в темных цветовых решениях.



# CODICI E FORMATI

CODES AND SIZES / ARTIKELNR. UND FORMATE / CODES ET FORMATS / КОДЫ И ФОРМАТЫ

FINITURA /  
FINISH /  
OBERFLÄCHENAUFÜHRUNG /  
FINITION /  
ПОВЕРХНОСТЬ



120x30  
48"x12"

10 mm



120x20  
48"x8"

10 mm



120x15  
48"x6"

10 mm



60x10  
24"x4"

10 mm



90x22,5  
36"x9"

10 mm



90x15  
36"x6"

10 mm



90x11  
36"x4<sup>1/2</sup>"

10 mm

ROVERE ABBAZIA	AN	-	-	-	-	PAR22364	PAR15364	PAR11364
ROVERE ANTICO	AN	-	-	-	-	PAR22334	PAR15334	PAR11334
ROVERE BIANCO	AN	-	-	-	-	PAR22342	PAR15342	PAR11342
ROVERE BIANCO	ACTIVE	AN	-	-	-	PAR22342AC	PAR15342AC	PAR11342AC
ROVERE BIONDO	AN	-	-	-	-	PAR22322	PAR15322	PAR11322
ROVERE BIONDO	ACTIVE	AN	-	-	-	PAR22322AC	PAR15322AC	PAR11322AC
ROVERE BRICCOLA	AN	PAR30425	PAR20425	PAR115425	PAR10425			
ROVERE CENERE	AN	PAR30397	PAR20397	PAR115397	PAR10397	-	-	-
ROVERE CHIARO	AN	-	-	-	-	PAR22321	PAR15321	PAR11321
ROVERE CILIEGIO	AN	-	-	-	-	PAR22336	PAR15336	PAR11336
ROVERE CORDA	AN	PAR30379	PAR20379	PAR115379	PAR10379	-	-	-
ROVERE CORDA	ACTIVE	AN	PAR30379AC	PAR20379AC	PAR115379AC	-	-	-
ROVERE COUNTRY	AN	PAR30426	PAR20426	PAR115426	PAR10426			
ROVERE DECAPÈ	AN	PAR30389	PAR20389	PAR115389	PAR10389	-	-	-
ROVERE GRIGIO	AN	-	-	-	-	PAR22335	PAR15335	PAR11335
ROVERE GRIGIO	ACTIVE	AN	-	-	-	PAR22335AC	PAR15335AC	PAR11335AC
ROVERE IMPERO	AN	PAR30386	PAR20386	PAR115386	PAR10386	-	-	-
ROVERE MOKA	AN	PAR30323	PAR20323	PAR115323	PAR10323	PAR22323	PAR15323	PAR11323
ROVERE MOKA	ACTIVE	AN	-	-	-	PAR22323AC	PAR15323AC	PAR11323AC
ROVERE MORO	AN	PAR30398	PAR20398	PAR115398	PAR10398	-	-	-
ROVERE NATURALE	AN	-	-	-	-	PAR22365	PAR15365	PAR11365
ROVERE NATURALE	ACTIVE	AN	-	-	-	PAR22365AC	PAR15365AC	PAR11365AC
ROVERE NERO	AN	-	-	-	-	PAR22320	PAR15320	PAR11320
ROVERE NOCE	AN	PAR30395	PAR20395	PAR115395	PAR10395	-	-	-
ROVERE PROVENZALE	AN	PAR30424	PAR20424	PAR115424	PAR10424			
ROVERE REALE	AN	PAR30387	PAR20387	PAR115387	PAR10387	-	-	-
ROVERE SABBIA	AN	PAR30396	PAR20396	PAR115396	PAR10396	-	-	-
ROVERE SCURO	AN	PAR30388	PAR20388	PAR115388	PAR10388	-	-	-
ROVERE TUNDRA	AN	PAR30380	PAR20380	PAR115380	PAR10380	-	-	-

**AN** ANTICATO /  
Antiqued / Antik /  
Antique / С эффектом искусственного старения

RETTIFICATO MONOCALIBRO /  
Rectified single-calibre / Rektifiziert einkalbrig /  
Rectifié monocalibre / Исправленное и монокалибр

SPESSORE /  
Thickness: / Dicke: /  
Épaisseur: / Толщина

▼  
**10 mm**  
▲

# PEZZI SPECIALI

TRIMS / FORMTEILE / PIÈCES SPÉCIALES / СПЕЦИАЛЬНЫЕ ЭЛЕМЕНТЫ

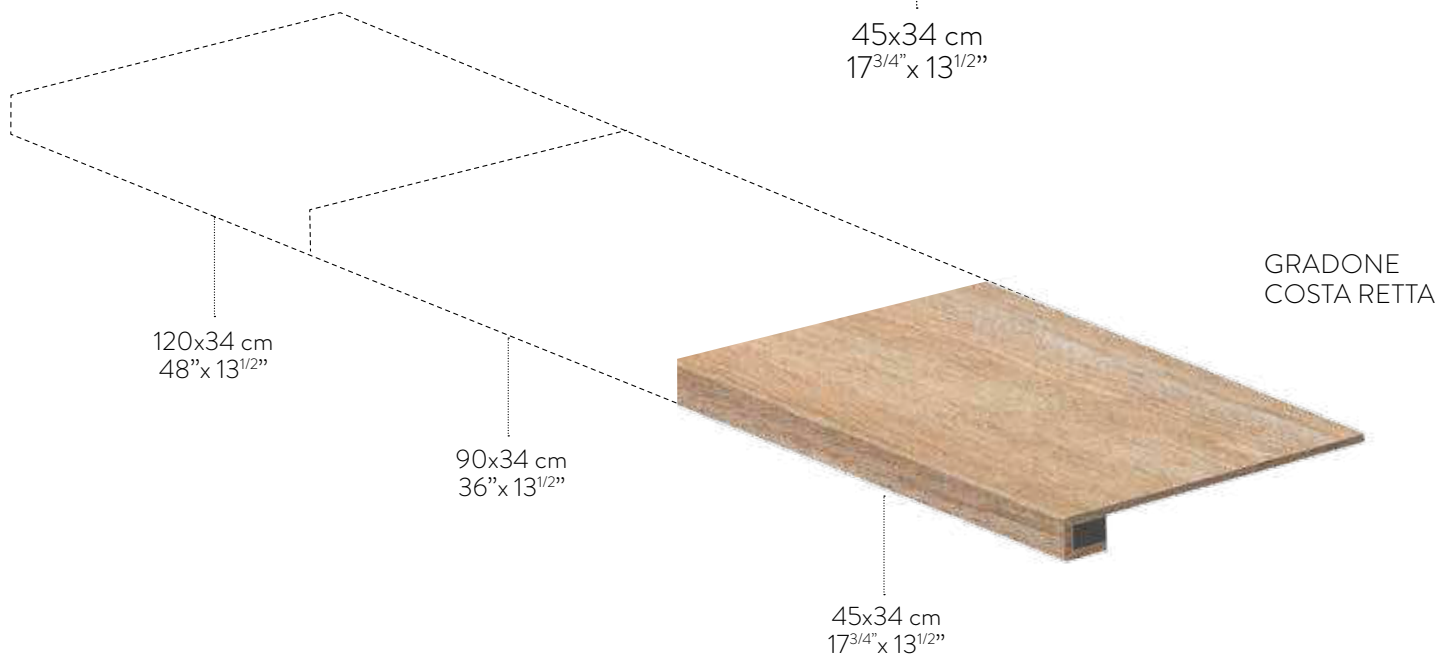
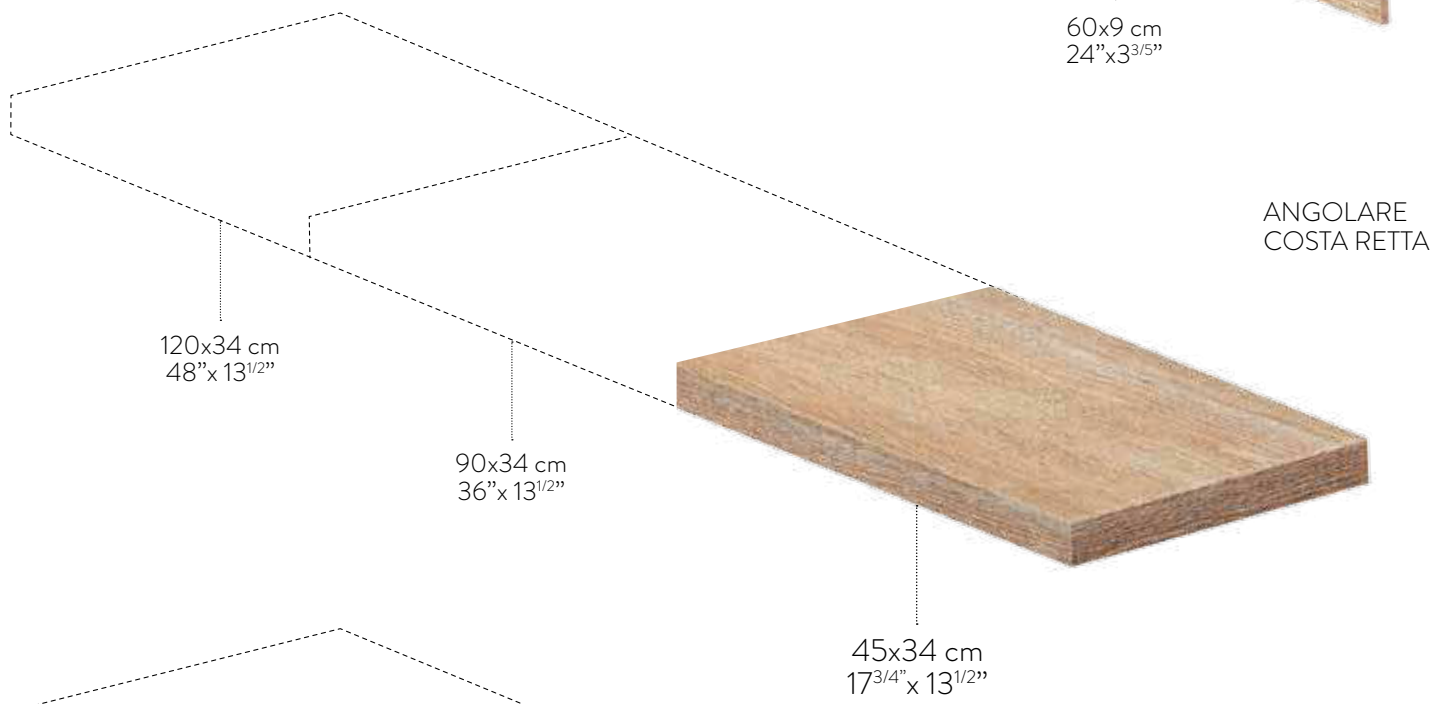
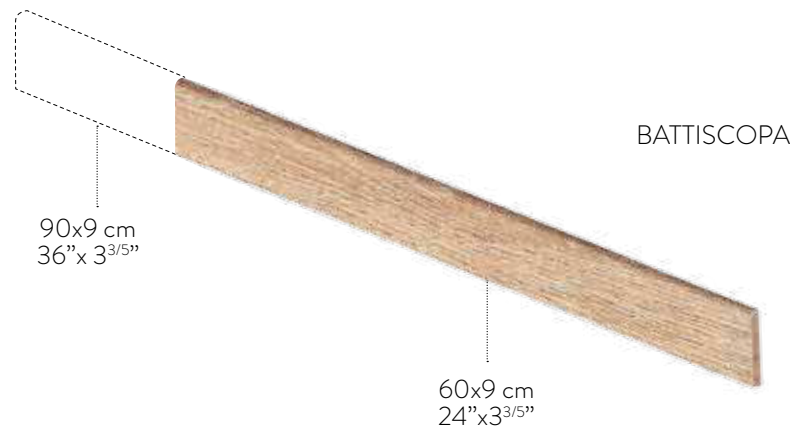



# CODICI E FORMATI

CODES AND SIZES / ARTIKELNR. UND FORMATE / CODES ET FORMATS / КОДЫ И ФОРМАТЫ



BATTISCOPA /  
BULLNOSE /  
STEHSCOCKEL /  
PLINTHE /  
ПЛИНТУС

90x9 (36"x 3 <sup>3/5</sup> "	ROVERE ABBAZIA	<b>BA90364T</b>
	ROVERE ANTICO	<b>BA90334T</b>
	ROVERE BIANCO	<b>BA90342T</b>
	ROVERE BIONDO	<b>BA90322T</b>
	ROVERE CHIARO	<b>BA90321T</b>
	ROVERE CILIEGIO	<b>BA90336T</b>
	ROVERE GRIGIO	<b>BA90335T</b>
	ROVERE MOKA	<b>BA90323T</b>
	ROVERE NATURALE	<b>BA90365T</b>
	ROVERE NERO	<b>BA90320T</b>

60x9 (24"x 3 <sup>3/5</sup> "	ROVERE BRICCOLA	<b>BA9425T</b>
	ROVERE CENERE	<b>BA9397T</b>
	ROVERE CORDA	<b>BA9379T</b>
	ROVERE COUNTRY	<b>BA9426T</b>
	ROVERE DECAPÈ	<b>BA9389T</b>
	ROVERE IMPERO	<b>BA9386T</b>
	ROVERE MOKA	<b>BA9323T</b>
	ROVERE MORO	<b>BA9398T</b>
	ROVERE NOCE	<b>BA9395T</b>
	ROVERE PROVENZALE	<b>BA9424T</b>
	ROVERE REALE	<b>BA9387T</b>
	ROVERE SABBIA	<b>BA9396T</b>
	ROVERE SCURO	<b>BA9388T</b>
	ROVERE TUNDRA	<b>BA9380T</b>



GRADONE  
COSTA RETTA /  
COSTA RETTA  
STEP TREAD /  
STUFE COSTA RETTA /  
NEZ DE MARCHE  
COSTA RETTA /  
СТУПЕНЬ COSTA RETTA

120x34 (48"x 13 <sup>1/2</sup> "	ROVERE BRICCOLA	<b>PGRA12425</b>
	ROVERE CENERE	<b>PGRA12397</b>
	ROVERE CORDA	<b>PGRA12379</b>
	ROVERE COUNTRY	<b>PGRA12426</b>
	ROVERE DECAPÈ	<b>PGRA12389</b>
	ROVERE IMPERO	<b>PGRA12386</b>
	ROVERE MOKA	<b>PGRA12323</b>
	ROVERE MORO	<b>PGRA12398</b>
	ROVERE NOCE	<b>PGRA12395</b>
	ROVERE PROVENZALE	<b>PGRA12424</b>
	ROVERE REALE	<b>PGRA12387</b>
	ROVERE SABBIA	<b>PGRA12396</b>
	ROVERE SCURO	<b>PGRA12388</b>
	ROVERE TUNDRA	<b>PGRA12380</b>

90x34 (36"x 13 <sup>1/2</sup> "	ROVERE ABBAZIA	<b>PGRA90364</b>
	ROVERE ANTICO	<b>PGRA90334</b>
	ROVERE BIANCO	<b>PGRA90342</b>
	ROVERE BIONDO	<b>PGRA90322</b>
	ROVERE CHIARO	<b>PGRA90321</b>
	ROVERE CILIEGIO	<b>PGRA90336</b>
	ROVERE GRIGIO	<b>PGRA90335</b>
	ROVERE MOKA	<b>PGRA90323</b>
	ROVERE NATURALE	<b>PGRA90365</b>
	ROVERE NERO	<b>PGRA90320</b>

45X34 (17 <sup>3/4</sup> "x 13 <sup>1/2</sup> "	ROVERE ABBAZIA	<b>PGRA45364</b>
	ROVERE ANTICO	<b>PGRA45334</b>
	ROVERE BIANCO	<b>PGRA45342</b>
	ROVERE BIONDO	<b>PGRA45322</b>
	ROVERE CHIARO	<b>PGRA45321</b>
	ROVERE CILIEGIO	<b>PGRA45336</b>
	ROVERE GRIGIO	<b>PGRA45335</b>
	ROVERE MOKA	<b>PGRA45323</b>
	ROVERE NATURALE	<b>PGRA45365</b>
	ROVERE NERO	<b>PGRA45320</b>



ANGOLARE  
COSTA RETTA /  
COSTA RETTA  
STEP TREAD  
CORNER /  
ECKESTUFE  
COSTA RETTA /  
NEZ DE MARCHE  
COSTA RETTA  
AVEC ANGLE /  
УГЛОВАЯ СТУПЕНЬ  
COSTA RETTA

120x34 (48"x 13 <sup>1/2</sup> "	ROVERE BRICCOLA	<b>PRAA12425</b>
	ROVERE CENERE	<b>PRAA12397</b>
	ROVERE CORDA	<b>PRAA12379</b>
	ROVERE COUNTRY	<b>PRAA12426</b>
	ROVERE DECAPÈ	<b>PRAA12389</b>
	ROVERE IMPERO	<b>PRAA12386</b>
	ROVERE MOKA	<b>PRAA12323</b>
	ROVERE MORO	<b>PRAA12398</b>
	ROVERE NOCE	<b>PRAA12395</b>
	ROVERE PROVENZALE	<b>PRAA12424</b>
ROVERE REALE	<b>PRAA12387</b>	
ROVERE SABBIA	<b>PRAA12396</b>	
ROVERE SCURO	<b>PRAA12388</b>	
ROVERE TUNDRA	<b>PRAA12380</b>	

90x34 (36"x 13 <sup>1/2</sup> "	ROVERE ABBAZIA	<b>PRAA90364</b>
	ROVERE ANTICO	<b>PRAA90334</b>
	ROVERE BIANCO	<b>PRAA90342</b>
	ROVERE BIONDO	<b>PRAA90322</b>
	ROVERE CHIARO	<b>PRAA90321</b>
	ROVERE CILIEGIO	<b>PRAA90336</b>
	ROVERE GRIGIO	<b>PRAA90335</b>
	ROVERE MOKA	<b>PRAA90323</b>
	ROVERE NATURALE	<b>PRAA90365</b>
	ROVERE NERO	<b>PRAA90320</b>

45X34 (17 <sup>3/4</sup> "x 13 <sup>1/2</sup> "	ROVERE ABBAZIA	<b>PRAA45364</b>
	ROVERE ANTICO	<b>PRAA45334</b>
	ROVERE BIANCO	<b>PRAA45342</b>
	ROVERE BIONDO	<b>PRAA45322</b>
	ROVERE CHIARO	<b>PRAA45321</b>
	ROVERE CILIEGIO	<b>PRAA45336</b>
	ROVERE GRIGIO	<b>PRAA45335</b>
	ROVERE MOKA	<b>PRAA45323</b>
	ROVERE NATURALE	<b>PRAA45365</b>
	ROVERE NERO	<b>PRAA45320</b>

# MOSAICI

MOSAICS / MOSAIKEN / MOSAÏQUES / МОЗАИКИ

MINI DOMINO  
30X30 cm 12"x12"



Disponibile in tutti colori della serie/  
Available in all the colours of the collection/  
Verfügbar in allen Farben der Serie/  
Disponibile dans toutes les couleurs de la série /  
Доступно во всех цветах серии

CLASSIC  
30X30 cm 12"x12"

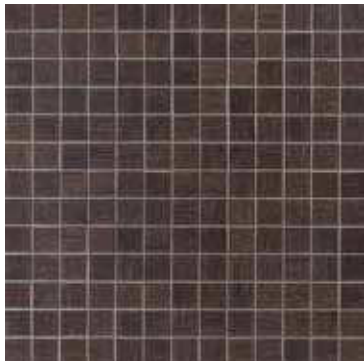

Disponibile in tutti colori della serie/  
Available in all the colours of the collection/  
Verfügbar in allen Farben der Serie/  
Disponibile dans toutes les couleurs de la série /  
Доступно во всех цветах серии

DOMINO  
30X30 cm 12"x12"



Disponibile in tutti colori della serie/  
Available in all the colours of the collection/  
Verfügbar in allen Farben der Serie/  
Disponibile dans toutes les couleurs de la série /  
Доступно во всех цветах серии

MULTILAMA  
30X15 cm 12"x6"



Disponibile in tutti colori della serie/  
Available in all the colours of the collection/  
Verfügbar in allen Farben der Serie/  
Disponibile dans toutes les couleurs de la série /  
Доступно во всех цветах серии

MULTILAMA MIX 1  
30X15 cm 12"x6"

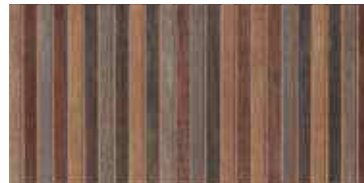

ROVERE ANTICO  
ROVERE BIONDO  
ROVERE CILIEGIO  
ROVERE MOKA

MULTILAMA MIX 2  
30X15 cm 12"x6"



ROVERE CHIARO  
ROVERE GRIGIO  
ROVERE NERO

MAXILAMA  
90X22,5 cm 36"x9"

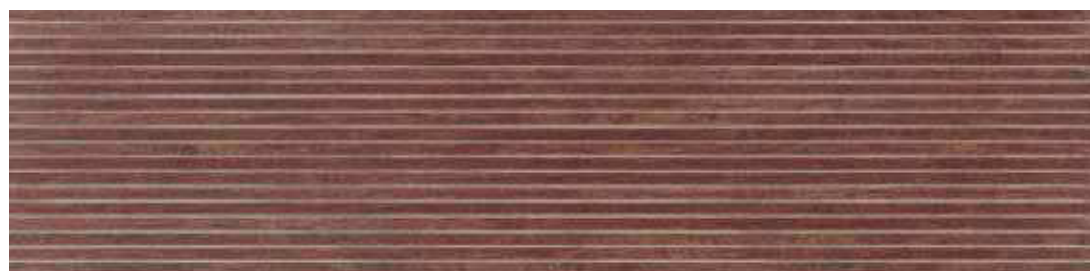

ROVERE ABBAZIA  
ROVERE ANTICO  
ROVERE BIANCO  
ROVERE BIONDO  
ROVERE CHIARO  
ROVERE CILIEGIO  
ROVERE GRIGIO  
ROVERE MOKA  
ROVERE NATURALE  
ROVERE NERO

# CODICI E FORMATI

CODES AND SIZES / ARTIKELNR. UND FORMATE / CODES ET FORMATS / КОДЫ И ФОРМАТЫ

	30x15 (12"x6")	MULTILAMA ROVERE ABBAZIA	LAM15364
		MULTILAMA ROVERE ANTICO	LAM15334
		MULTILAMA ROVERE BIANCO	LAM15342
		MULTILAMA ROVERE BIONDO	LAM15322
		MULTILAMA ROVERE BRICCOLA	LAM15425
		MULTILAMA ROVERE CENERE	LAM15397
		MULTILAMA ROVERE CHIARO	LAM15321
		MULTILAMA ROVERE CILIEGIO	LAM15336
		MULTILAMA ROVERE CORDA	LAM15379
		MULTILAMA ROVERE COUNTRY	LAM15426
		MULTILAMA ROVERE DECAPÈ	LAM15389
		MULTILAMA ROVERE GRIGIO	LAM15335
		MULTILAMA ROVERE IMPERO	LAM15386
		MULTILAMA ROVERE MOKA	LAM15323
		MULTILAMA ROVERE MORO	LAM15398
		MULTILAMA ROVERE NATURALE	LAM15365
		MULTILAMA ROVERE NERO	LAM15320
		MULTILAMA ROVERE NOCE	LAM15395
		MULTILAMA ROVERE PROVENZALE	LAM15424
		MULTILAMA ROVERE REALE	LAM15387
	MULTILAMA ROVERE SABBIA	LAM15396	
	MULTILAMA ROVERE SCURO	LAM15388	
	MULTILAMA ROVERE TUNDRA	LAM15380	

	30x15 (12"x6")	MULTILAMA MIX 1	
		ROVERE BIONDO/MOKA/ANTICO/CILIEGIO	LAM15MIX1

	30x15 (12"x6")	MULTILAMA MIX 2	
		ROVERE CHIARO/NERO/GRIGIO	LAM15MIX2

	30x30 (12"x12")	MINI DOMINO ROVERE ABBAZIA	DOMM364
		MINI DOMINO ROVERE ANTICO	DOMM334
		MINI DOMINO ROVERE BIANCO	DOMM342
		MINI DOMINO ROVERE BIONDO	DOMM322
		MINI DOMINO ROVERE BRICCOLA	DOMM425
		MINI DOMINO ROVERE CENERE	DOMM397
		MINI DOMINO ROVERE CHIARO	DOMM321
		MINI DOMINO ROVERE CILIEGIO	DOMM336
		MINI DOMINO ROVERE CORDA	DOMM379
		MINI DOMINO ROVERE COUNTRY	DOMM426
		MINI DOMINO ROVERE DECAPÈ	DOMM389
		MINI DOMINO ROVERE GRIGIO	DOMM335
		MINI DOMINO ROVERE IMPERO	DOMM386
		MINI DOMINO ROVERE MOKA	DOMM323
		MINI DOMINO ROVERE MORO	DOMM398
		MINI DOMINO ROVERE NATURALE	DOMM365
		MINI DOMINO ROVERE NERO	DOMM320
		MINI DOMINO ROVERE NOCE	DOMM395
		MINI DOMINO ROVERE PROVENZALE	DOMM424
		MINI DOMINO ROVERE REALE	DOMM387
		MINI DOMINO ROVERE SABBIA	DOMM396
		MINI DOMINO ROVERE SCURO	DOMM388
		MINI DOMINO ROVERE TUNDRA	DOMM380

	30x30 (12"x12")	CLASSIC ROVERE ABBAZIA	MC364
		CLASSIC ROVERE ANTICO	MC334
		CLASSIC ROVERE BIANCO	MC342
		CLASSIC ROVERE BIONDO	MC322
		CLASSIC ROVERE BRICCOLA	MC425
		CLASSIC ROVERE CENERE	MC397
		CLASSIC ROVERE CHIARO	MC321
		CLASSIC ROVERE CILIEGIO	MC336
		CLASSIC ROVERE CORDA	MC379
		CLASSIC ROVERE COUNTRY	MC426
		CLASSIC ROVERE DECAPÈ	MC389
		CLASSIC ROVERE GRIGIO	MC335
		CLASSIC ROVERE IMPERO	MC386

CLASSIC ROVERE MOKA	MC323
CLASSIC ROVERE MORO	MC398
CLASSIC ROVERE NATURALE	MC365
CLASSIC ROVERE NERO	MC320
CLASSIC ROVERE NOCE	MC395
CLASSIC ROVERE PROVENZALE	MC424
CLASSIC ROVERE REALE	MC387
CLASSIC ROVERE SABBIA	MC396
CLASSIC ROVERE SCURO	MC388
CLASSIC ROVERE TUNDRA	MC380

	30x30 (12"x12")	DOMINO ROVERE ABBAZIA	DOM364
		DOMINO ROVERE ANTICO	DOM334
		DOMINO ROVERE BIANCO	DOM342
		DOMINO ROVERE BIONDO	DOM322
		DOMINO ROVERE BRICCOLA	DOM425
		DOMINO ROVERE CENERE	DOM397
		DOMINO ROVERE CHIARO	DOM321
		DOMINO ROVERE CILIEGIO	DOM336
		DOMINO ROVERE CORDA	DOM379
		DOMINO ROVERE COUNTRY	DOM426
		DOMINO ROVERE DECAPÈ	DOM389
		DOMINO ROVERE GRIGIO	DOM335
		DOMINO ROVERE IMPERO	DOM386
		DOMINO ROVERE MOKA	DOM323
		DOMINO ROVERE MORO	DOM398
		DOMINO ROVERE NATURALE	DOM365
		DOMINO ROVERE NERO	DOM320
		DOMINO ROVERE NOCE	DOM395
		DOMINO ROVERE PROVENZALE	DOM424
		DOMINO ROVERE REALE	DOM387
	DOMINO ROVERE SABBIA	DOM396	
	DOMINO ROVERE SCURO	DOM388	
	DOMINO ROVERE TUNDRA	DOM380	

	90x22,5 (36"x9")	MAXILAMA ROVERE ABBAZIA	LAM22364
		MAXILAMA ROVERE ANTICO	LAM22334
		MAXILAMA ROVERE BIANCO	LAM22342
		MAXILAMA ROVERE BIONDO	LAM22322
		MAXILAMA ROVERE CHIARO	LAM22321
		MAXILAMA ROVERE CILIEGIO	LAM22336
		MAXILAMA ROVERE GRIGIO	LAM22335
		MAXILAMA ROVERE MOKA	LAM22323
		MAXILAMA ROVERE NATURALE	LAM22365
		MAXILAMA ROVERE NERO	LAM22320

# CARATTERISTICHE TECNICHE

TECHNICAL FEATURES / TECHNISCHE EIGENSCHAFTEN / CARACTÉRISTIQUES TECHNIQUES / ЕХНИЧЕСКИЕ ХАРАКТЕРИСТИКИ

CLASSIFICAZIONE SECONDO NORME CEN E ISO GRUPPO B1a EN 14411 ALL.G E ISO 13006 ALL.G / CLASSIFICATION IN ACCORDANCE WITH CEN AND ISO STANDARDS B1a EN 14411 ENCLOSED G AND ISO 13006 ENCL. G / KLASSIFIZIERUNG GEMÄß CEN UND ISO NORMEN GRUPPE B1a EN 14411 ANL. G UND ISO 13006 ANL.G / CLASSIFICATION SELON LES NORMES CEN ET ISO GROUPE B1a EN 14411 P.J.G ET ISO 13006 P.J.G / КЛАССИФИКАЦИЯ В СООТВЕТСТВИИ С СТАНДАРТАМИ CEN И ISO B1a EN 14411 ВЛОЖЕННЫХ Г И ISO 13006 ВЛОЖЕННЫХ Г

PROPRIETÀ CHIMICO - FISICHE /  
CHEMICAL / PHYSICAL PROPERTIES /  
CHEMISCH PHYSISCHE EIGENSCHAFTEN /  
PROPRIÉTÉS CHIMICO - PHYSIQUES /  
СВОЙСТВА ХИМИЧЕСКИМИ - ФИЗИЧЕСКИМИ

NORMA /  
REGULATION /  
NORMEN /  
NORME /  
НОРМА

VALORE PRESCRITTO /  
REQUIRED VALUE /  
VORGESCHRIEBENER WERT /  
VALUER PRESCRITE /  
ПРЕДУСМОТРЕННЫЕ ЗНАЧЕНИЯ

VALORI MEDI ARIOSTEA /  
ARIOSTEA AVERAGE VALUES /  
ARIOSTEA DURCHSCHNITTSWERTE /  
VALEURS MOYENNES ARIOSTEA /  
СРЕДНИЕ ЗНАЧЕНИЯ ARIOSTEA



ASSORBIMENTO D'ACQUA  
WATER ABSORPTION / WASSERAUFNAHME /  
ABSORPTION D'EAU / ВОДОПОГЛОЩЕНИЕ

ISO 10545-3

≤ 0,5 %

0,02% - 0,04%



DIMENSIONI  
SIZES / ABMESSUNGEN /  
DIMENSIONS / ФОРМАТЫ

ISO 10545-2

± 0,6% max  
LUNGHEZZA E LARGHEZZA / LENGHT AND WIDTH / LÄNGE UND  
BREITE / LONGUEUR ET LARGEUR / ДЛИНА И ШИРИНА

± 0,1%  
LUNGHEZZA E LARGHEZZA / LENGHT AND WIDTH / LÄNGE UND  
BREITE / LONGUEUR ET LARGEUR / ДЛИНА И ШИРИНА

± 5% max  
SPESSORE / THICKNESS / STÄRKE / EPAISSEUR / ТОЛЩИНА

± 5%  
SPESSORE / THICKNESS / STÄRKE / EPAISSEUR / ТОЛЩИНА

± 0,5% max  
RETTILINEITÀ SPIGOLI / LINEARITY / KANTENGERADHEIT /  
RECTITUDE DES ARÊTES / ЧЕСТНОСТЬ ОСТРЫХ КРАЕВ

± 0,1%  
RETTILINEITÀ SPIGOLI / LINEARITY / KANTENGERADHEIT /  
RECTITUDE DES ARÊTES / ЧЕСТНОСТЬ ОСТРЫХ КРАЕВ

± 0,6% max  
ORTOGONALITÀ / WEDGING / RECHTWINKLIGKEIT /  
ORTHOGONALITÉ / ОРТОГОНАЛЬНОСТИ

± 0,1%  
ORTOGONALITÀ / WEDGING / RECHTWINKLIGKEIT /  
ORTHOGONALITÉ / ОРТОГОНАЛЬНОСТИ

± 0,5% max  
PLANARITÀ / WARPAGE / EBENFLÄCHIGKEIT /  
PLANÉITÉ / ПЛОСКОСТНОСТИ

± 0,2%  
PLANARITÀ / WARPAGE / EBENFLÄCHIGKEIT /  
PLANÉITÉ / ПЛОСКОСТНОСТИ



ASPETTO / APPEARANCE /  
AUSSEHEN / ASPECT / АСПЕКТ

95% MIN. ESENTE DA DIFETTI / MIN. 95% DEFECT FREE  
/ MINDESTENS ZU 95% FEHLERFREI / 95% MIN. SANS  
DÉFAUTS / МИН. 95% БЕЗ ДЕФЕКТОВ

CONFORME / CONFORMS / KONFORM /  
CONFORME / СООТВЕТСТВУЕТ



RESISTENZA ALL'ABRASIONE PROFONDA /  
DEEP ABRASION RESISTANCE /  
TIEFVERSCHLEISSBESTÄNDIGKEIT /  
RESISTANCE A L'ABRASION PROFONDE /  
ИЗНОСОУСТОЙЧИВОСТЬ

ISO 10545-6

max 175 mm<sup>3</sup>

130 mm<sup>3</sup>



RESISTENZA AI PRODOTTI CHIMICI  
RESISTANCE TO CHEMICAL PRODUCTS /  
CHEMIKALIENBESTÄNDIGKEIT / RESISTANCE AUX  
PRODUITS CHIMIQUES / ХИМИЧЕСКАЯ УСТОЙЧИВОСТЬ

ISO 10545-13

UBmin

CONFORME / CONFORMS / KONFORM /  
CONFORME / СООТВЕТСТВУЕТ



RESISTENZA ALLE MACCHIE  
STAIN RESISTANCE / FLECKENBESTÄNDIGKEIT  
/ RESISTANCE AUX TACHES / УСТОЙЧИВОСТЬ К  
ПЯТНООБРАЗОВАНИЮ

ISO 10545-14

METODO DI PROVA DISPONIBILE / TESTING METHOD AVAILABLE/  
VERFÜGBARES PRÜFVERFAHREN/ MÉTHODE D'ESSAI  
DISPONIBILE / ИМЕЕТСЯ МЕТОДИКА ИСПЫТАНИЙ

CLASSE 5 / CLASS 5 / KLASSE 5 /  
CLASSE 5 / КЛАСС - 5



MODULO DI ROTTURA (R)  
MODULS OF RUPTURE (R) / BRUCHMODUL (R) /  
MODULE DE RUPTURE (R) / ПРОЧНОСТЬ НА ИЗГИБ

ISO 10545-4

≥ 35 N/mm<sup>2</sup>

50 N/mm<sup>2</sup>



RESISTENZA SBALZI TERMICI  
RESISTANCE TO THERMAL SHOCKS /  
TEMPERATURWECHSELBESTÄNDIGKEIT / RESISTANCE  
AUX ECARTS DE TEMPERATURE / УСТОЙЧИВОСТЬ К  
РЕЗКИМ ПЕРЕПАДАМ ТЕМПЕРАТУР

ISO 10545-9

METODO DI PROVA DISPONIBILE / TESTING METHOD AVAILABLE/  
VERFÜGBARES PRÜFVERFAHREN/ MÉTHODE D'ESSAI  
DISPONIBILE / ИМЕЕТСЯ МЕТОДИКА ИСПЫТАНИЙ

RESISTENTE / RESISTANT /  
BESTÄNDIG / RESISTANT / УСТОЙЧИВ



RESISTENZA COLORI ALLA LUCE  
RESISTANCE TO LIGHT/LICHTBESTÄNDIGKEIT DER  
FARBEN/RESISTANCE DES COULEURS A LA LUMIERE /  
УСТОЙЧИВОСТЬ ЦВЕТА К ВЫГОРАНИЮ

DIN 51094

SUP. INALTERATA / UNAFFECTED SURFACE /  
OBERFLÄCHE UNVERÄNDERT / SURFACE INALTEREE /  
ПОВЕРХНОСТЬ БЕЗ ИЗМЕНЕНИЙ



DILATAZIONE TERMICA LINEARE  
COEFFICIENT OF LINEAR THERMAL EXPANSION /  
LINEARER WÄRMEAUSSDEHNUNGSKOEFFIZIENT /  
DILATATION THERMIQUE LINEAIRE / КОЭФФИЦИЕНТ  
ТЕПЛОВОГО РАСШИРЕНИЯ

ISO 10545-8

METODO DI PROVA DISPONIBILE / TESTING METHOD AVAILABLE/  
VERFÜGBARES PRÜFVERFAHREN/ MÉTHODE D'ESSAI  
DISPONIBILE / ИМЕЕТСЯ МЕТОДИКА ИСПЫТАНИЙ

6,2X10<sup>-6</sup> °C<sup>-1</sup>



RESISTENZA AL GELO / FROST RESISTANCE /  
FROSTBESTÄNDIGKEIT / RESISTANCE AU GEL /  
МОРОЗОУСТОЙЧИВОСТЬ

ISO 10545-12

RICHIESTI 100 CICLI DI GELO-DISGELO / REQUESTED 100  
FREEZE-THAW CYCLES / 100 GEFRIER-AUFTAUZYKLEN  
ANGEFRAGT / DEMANDÉE 100 CYCLES DE GEL-DÉGEL /  
ТРЕБУЕТСЯ 100 ЦИКЛОВ ЗАМОРАЖИВАНИЯ

RESISTENTE / RESISTANT /  
BESTÄNDIG / RESISTANT / УСТОЙЧИВ



COEFFICIENTE DI ATTRITO / FRICTION COEFFICIENT /  
REIBUNGSKOEFFIZIENT / COEFFICIENT DE FRICTION  
/ СОПРОТИВЛЯЕМОСТЬ СКОЛЬЖЕНИЮ

DIN 51130/51097







\*

STANDARDS ANSI/ASTM DISPONIBILI A RICHIESTA /  
ANSI/ASTM STANDARDS AVAILABLE ON DEMAND /  
ANSI/ASTM STANDARDS VERFÜGBARE AUF ANFRAGE /  
ANSI/ASTM STANDARDS DISPONIBLES SUR DEMANDE /  
ANSI/ASTM STANDARDS ПРЕДОСТАВЛЯЕТСЯ ПО ЗАПРОСУ



\* VEDI TABELLA SAFE SYSTEM /  
SEE SAFE SYSTEM TABLE /  
SIEHE TABELLE SAFE SYSTEM /  
VOIR TABLEAU SAFE SYSTEM /  
СР./ SAFE SYSTEM

# IMBALLAGGI E PESI





PACKING AND WEIGHTS / VERPACKUNG UND GEWICHT / EMBALLAGES ET POIDS / УПАКОВКА И ВЕС

	FORMATI SIZES FORMATE FORMAT ФОРМАТЫ	PEZZI SCATOLA PIECES BOX STÜCKE KARTON PIÈCES BOÎTE ШТУК В КОРОБКЕ	MQ. SCATOLA SQ. MT. BOX QM. KARTON m <sup>2</sup> BOÎTE М.КВ. В КОРОБКЕ	PESO SCATOLA WEIGHT BOX GEWICHT KARTON POIDS BOÎTE ВЕС КОРОБКИ KG	PESO MQ. SQ. MT. WEIGHT QM. GEWICHT POIDS m <sup>2</sup> ВЕС М.КВ. KG	SCATOLE PALLET BOX PALLET KARTON PALETTE BOÎTE PALETTE КОРОБОК В ПАЛLETTE	MQ. PALLET SQ. MT. PALLET QM. PALETTE m <sup>2</sup> PALETTE М.КВ. В ПАЛLETTE	PESO PALLET WEIGHT PALLET GEWICHT PALETTE POIDS PALETTE ВЕС ПАЛЛЕТА KG
	120 x 30	3	1,08	24,17	22,38	32	34,56	793,45
	120x 20	4	0,96	21,485	22,38	36	34,56	793,45
	120 x 15	6	1,08	24,17	22,38	36	38,88	890,14
	60 x 10	15	0,9	20,14	22,38	40	36,00	825,68
	90 x 22,5	6	1,215	27,27	22,42	36	43,74	1000,65
	90 x 15	9	1,215	27,24	22,42	36	43,74	1000,65
	90 x 11	11	1,089	24,42	22,42	40	43,56	996,62

## PEZZI SPECIALI / TRIMS / FORMTEILE / PIÈCES SPÉCIALES / СПЕЦИАЛЬНЫЕ ЭЛЕМЕНТЫ

	Battiscopa	90 x 9	6	5,4 LIN. MT.	12,60			
		60 x 9	10	6,0 LIN. MT.	12			
	Gradone costa retta	120 x 34	1	1,2 LIN. MT.	13,50			
		90 x 34	1	0,9 LIN. MT.	9,3			
		45 x 34	4	1,8 LIN. MT.	18,8			
	Angolare costa retta	120 x 34	1	1,2 LIN. MT.	14,50			
		90 x 35	1	0,9 LIN. MT.	10,30			
		45 x 34	2	0,9 LIN. MT.	10,40			

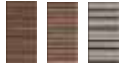
## MOSAICI / MOSAICS / MOSAIKEN / MOSAÏQUES / МОЗАИКИ

	Mini Domino	30 x 30	11	0,99	10,45				
	Classic	30 x 30	11	0,99	17,60				
	Domino	30 x 30	11	0,99	17,13	17,3	30	29,7	507,8
	Multilama Multilama mix 1 Multilama mix 2	30 x 15	8	0,36	7,52				
	Maxilama	90 x 22,5	6	1,215	25,8				

# SOLUZIONI DI POSA

LAYING SCHEMES / VERLEGUNGS SCHEMAS / PROPOSITIONS DE POSE / ВАРИАНТЫ УКЛАДКИ

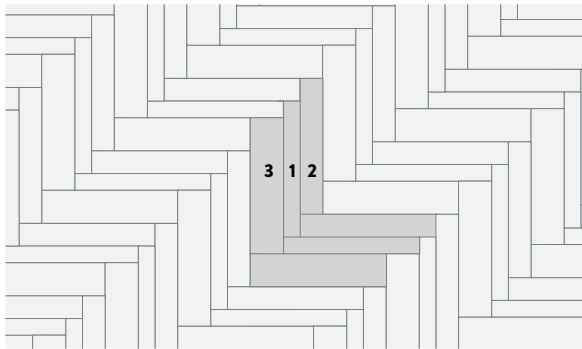

SPINA 3

- |                                |                               |
|--------------------------------|-------------------------------|
| <b>1</b> - 90x11 ant. 22,90%   | <b>1</b> - 120x15 ant. 23,10% |
| <b>2</b> - 90x15 ant. 30,80%   | <b>2</b> - 120x20 ant. 30,70% |
| <b>3</b> - 90x22,5 ant. 46,30% | <b>3</b> - 120x30 ant. 46,20% |

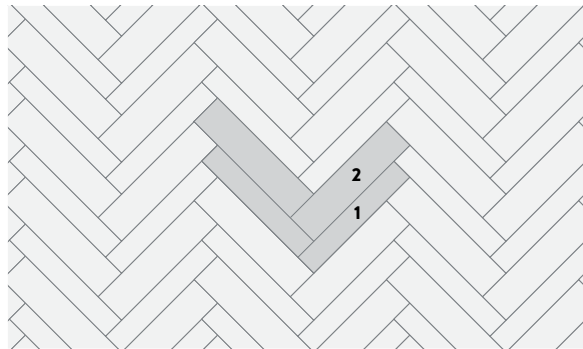

SPINA 2 DIAGONALE

- |                                |                               |
|--------------------------------|-------------------------------|
| <b>1</b> - 90x15 ant. 40%      | <b>1</b> - 120x20 ant. 40%    |
| <b>2</b> - 90x22,5 ant. 60%    | <b>2</b> - 120x30 ant. 60%    |
| <b>1</b> - 90x11 ant. 32,80%   | <b>1</b> - 120x15 ant. 33,40% |
| <b>2</b> - 90x22,5 ant. 67,20% | <b>2</b> - 120x30 ant. 66,60% |
| <b>1</b> - 90x11 ant. 42,30%   | <b>1</b> - 120x15 ant. 42,90% |
| <b>2</b> - 90x15 ant. 57,70%   | <b>2</b> - 120x20 ant. 57,10% |

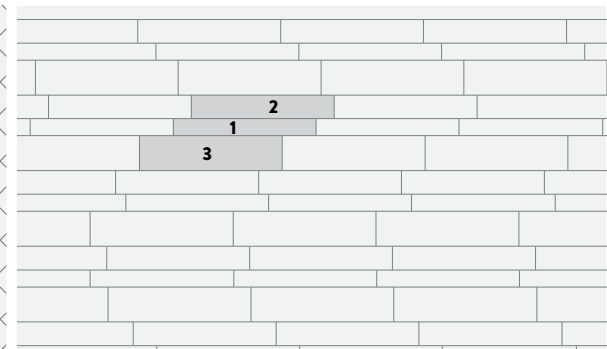

TOLDA 3

- |                                |                               |
|--------------------------------|-------------------------------|
| <b>1</b> - 90x11 ant. 22,90%   | <b>1</b> - 120x15 ant. 23,10% |
| <b>2</b> - 90x15 ant. 30,80%   | <b>2</b> - 120x20 ant. 30,70% |
| <b>3</b> - 90x22,5 ant. 46,30% | <b>3</b> - 120x30 ant. 46,20% |

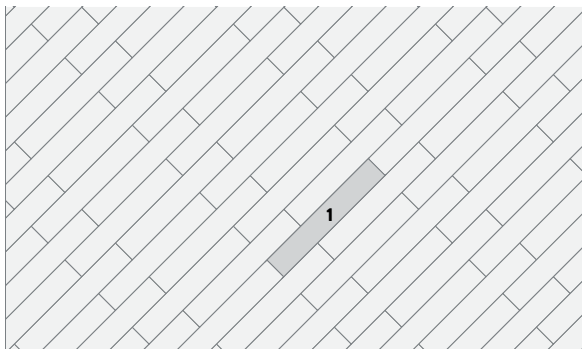

CASSERO DIAGONALE

- |                            |                             |
|----------------------------|-----------------------------|
| <b>1</b> - 90x15 ant. 100% | <b>1</b> - 120x15 ant. 100% |
|----------------------------|-----------------------------|

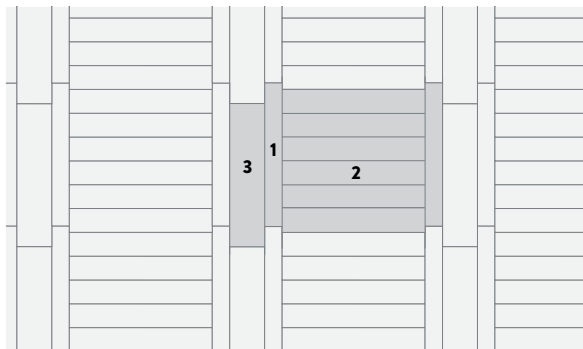

SPA 3

- |                                |                               |
|--------------------------------|-------------------------------|
| <b>1</b> - 90x11 ant. 16,30%   | <b>1</b> - 120x15 ant. 16,70% |
| <b>2</b> - 90x15 ant. 66,90%   | <b>2</b> - 120x20 ant. 66,60% |
| <b>3</b> - 90x22,5 ant. 16,80% | <b>3</b> - 120x30 ant. 16,70% |

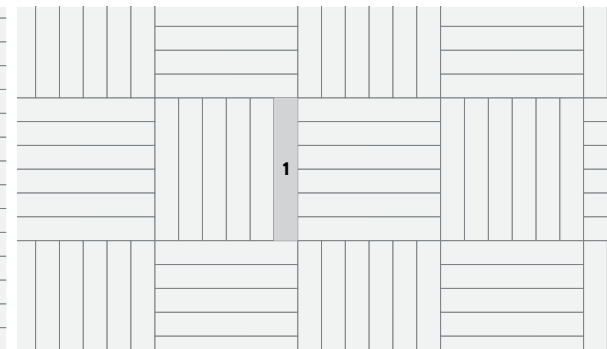

GARDEN

- |                              |                               |
|------------------------------|-------------------------------|
| <b>1</b> - 90x15 ant. 100% * | <b>1</b> - 120x20 ant. 100% * |
|------------------------------|-------------------------------|

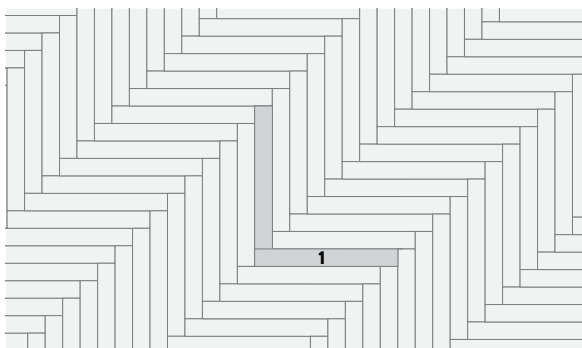

SPINA 1

- |                            |                             |
|----------------------------|-----------------------------|
| <b>1</b> - 90x11 ant. 100% | <b>1</b> - 120x15 ant. 100% |
|                            | <b>1</b> - 120x20 ant. 100% |

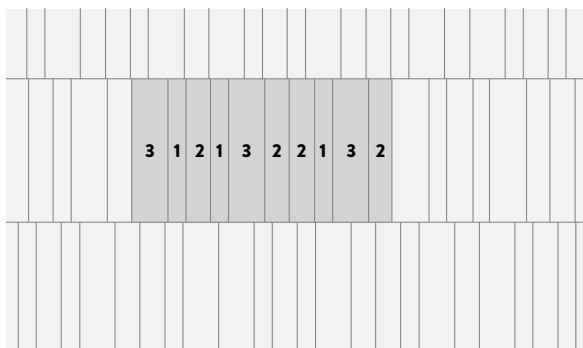

FRANCESE

- |                                |                               |
|--------------------------------|-------------------------------|
| <b>1</b> - 90x11 ant. 20,70%   | <b>1</b> - 120x15 ant. 24,20% |
| <b>2</b> - 90x15 ant. 37,20%   | <b>2</b> - 120x20 ant. 35,70% |
| <b>3</b> - 90x22,5 ant. 42,10% | <b>3</b> - 120x30 ant. 40,10% |

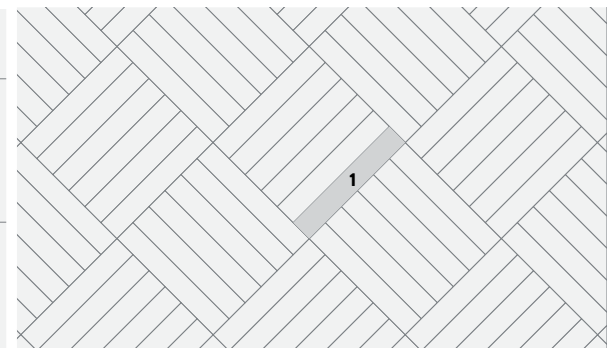

GARDEN DIAGONALE

- |                              |                               |
|------------------------------|-------------------------------|
| <b>1</b> - 90x15 ant. 100% * | <b>1</b> - 120x20 ant. 100% * |
|------------------------------|-------------------------------|

\* Posare con una fuga di 2 mm / Install the material with 2 mm of joint / Legen das Material mit 2 mm der Fuge an / Poser le matériel avec un joint de 2 mm. / стелить материал со швом в 2 мм.

# INFORMAZIONI TECNICHE AGGIUNTIVE

ADDITIONAL TECHNICAL INFORMATION / ZUSÄTZLICHE TECHNISCHE INFORMATIONEN / INFORMATION TECHNIQUE SUPPLÉMENTAIRE / ДОПОЛНИТЕЛЬНАЯ ТЕХНИЧЕСКАЯ ИНФОРМАЦИЯ

Lastre in porcellanato a tutto impasto realizzate con sistemi di multi caricamento brevettato a controllo computerizzato, classificabili secondo la norma europea EN 14411, internazionali ISO 13006 nel gruppo B1a e "impervious tile" secondo gli standard ANSI, aventi le seguenti caratteristiche tecniche (valori medi) misurate presso i nostri laboratori.

Full body porcelain stoneware slabs manufactured with multi-loading patented computer controlled technologies, classifiable according to the European EN 14411 regulation, international ISO 13006 in the B1a group regulation and the "impervious tile" definition (according to the ANSI standards), with the following technical features (average values) obtained in our laboratories.

Platten aus vollgemischtem Feinsteinzeug, die mit Hilfe von patentierten, computergesteuerten Mehrfachbeschichtungssystemen hergestellt werden und laut den europäischen Normen EN 14411 und den internationalen Normen ISO 13006, der Gruppe B1a eingeordnet sind und der Impervious tile laut den Standard ANSI, da sie folgende technische Eigenschaften (Durchschnittswerte), die in unseren Labors bewertet wurden, besitzen.

Plaques en grès cérame pleine masse réalisées avec des systèmes de chargement multiple breveté suivant un contrôle informatisé. Classables selon la norme européenne EN 14411, et la norme internationale ISO 13006 dans le group B1a et Impervious tile selon le standard ANSI, ayant les caractéristiques techniques suivantes (valeurs moyennes), mesurées dans nos laboratoires.

Полнотельный керамический гранит, производимый с использованием патентованной системой компьютерного контроля подачи сырья. Сертифицированный - по нормам EN 14411, ISO 13006 к группе B1a, и американским нормам ANSI, с соответствующими техническими характеристиками, которые контролируются нашей лабораторией.

I colori e le caratteristiche estetiche dei materiali illustrati nel presente catalogo sono da ritenersi puramente indicativi. La ditta Ariostea Spa si riserva di apportare modifiche senza preavviso ai prodotti, declinando ogni responsabilità per danni diretti o indiretti da eventuali modifiche.

Colors and optical features of all the items shown in this catalogue are to be regarded as mere indications. Ariostea Spa keeps the right to change all the mentioned items without notice and declining any responsibility for direct or indirect damage caused from these changes.

Die Farben und die ästhetischen Eigenschaften der in diesem Katalog illustrierten Materiale sind als unverbindlich zu betrachten. Die Firma Ariostea Spa behält sich vor, Änderungen an den Produkten ohne vorherige Benachrichtigung vorzunehmen und lehnt jegliche Verantwortung, für direkte oder indirekte Schäden von eventuellen Änderungen, ab.

Les couleurs et les caractéristiques esthétiques des matériaux illustrés dans ce catalogue sont à considérer comme purement indicatifs. La société Ariostea Spa se réserve le droit d'apporter, sans préavis, des modifications aux produits, et décline toute responsabilité pour dommages directs ou indirects, des éventuelles modifications.

Цвет и внешний вид материалов показанных в данном каталоге может отличаться от реальных плиток. Компания Ariostea Spa оставляет за собой право внесения изменений в ассортимент материалов без предварительного уведомления, и не несет ни какой ответственности за возможные прямые и не прямые проблемы, возникшие вследствие внесенных изменений.

## GRADO DI VARIAZIONE CROMATICA

DEGREE OF COLOUR CHANGE / GRAD DER FARBABWEICHUNG / DEGRE DE VARIATION CHROMATIQUE / УРОВЕНЬ ВАРИАЦИИ ЦВЕТА

ROVERE ABBAZIA	V3	ROVERE CENERE	V3	ROVERE DECAPÈ	V3	ROVERE NATURALE	V3	ROVERE SABBIA	V3
ROVERE ANTICO	V3	ROVERE CHIARO	V3	ROVERE MORO	V2	ROVERE NERO	V2	ROVERE SCURO	V3
ROVERE BIANCO	V2	ROVERE CILIEGIO	V3	ROVERE GRIGIO	V4	ROVERE NOCE	V4	ROVERE TUNDRA	V2
ROVERE BIONDO	V4	ROVERE CORDA	V3	ROVERE IMPERO	V4	ROVERE PROVENZALE	V3		
ROVERE BRICCOLA	V2	ROVERE COUNTRY	V3	ROVERE MOKA	V4	ROVERE REALE	V4		

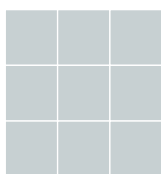

**V1 LOW**  
 PRODOTTO MONOCROMATICO  
 MONOCHROMATIC PRODUCT  
 EINFARBIGES PRODUKT  
 PRODUIT MONOCHROMATIQUE  
 МОНОХРОМНЫЙ ПРОДУКТ

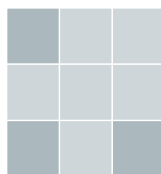

**V2 MODERATE**  
 PRODOTTO CON LEGGERA VARIAZIONE CROMATICA  
 PRODUCT WITH LIGHT CHROMATIC VARIATION  
 PRODUKT MIT LEICHTER FARBNUANCE  
 PRODUIT À LÉGÈRE VARIATION CHROMATIQUE  
 ПРОДУКТ С СИЛЬНОЙ ВАРИАЦИЕЙ ЦВЕТА

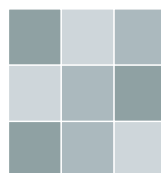

**V3 HIGH**  
 PRODOTTO CON MARCATA VARIAZIONE CROMATICA / PRODUCT WITH HIGH SHADE CHROMATIC VARIATION / PRODUKT MIT AUSGEPRAEGTER FARBNUANCE / PRODUIT À VARIATION CHROMATIQUE ACCENTUÉE / ПРОДУКТ С СИЛЬНОЙ ВАРИАЦИЕЙ ЦВЕТА

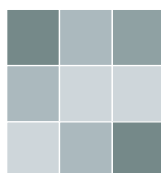

**V4 EXTREME**  
 PRODOTTO CON FORTE VARIAZIONE CROMATICA  
 PRODUCT WITH VERY HIGH SHADE CHROMATIC VARIATION  
 PRODUKT MIT STARKER FARBNUANCE  
 PRODUIT À FORTE VARIATION CHROMATIQUE  
 ПРОДУКТ С ОЧЕНЬ СИЛЬНОЙ ВАРИАЦИЕЙ ЦВЕТА

**ASTM C\_1028** COEFFICIENT OF FRICTION: DRY > 0.60 – WET > 0.60

**SPANISH PENDOLUM TEST ENV 12633:** class 2 (test performed on Rovere Biondo and Rovere Moka)

Per ottenere un ottimo risultato estetico è sempre preferibile posare il materiale con una fuga di 2 mm utilizzando stucature in tinta. For a better aesthetic result, it is always preferable to spread out the material with 2 mm of joint, jointing with tone on tone colours.

Um eine optimale Ästhetik zu erreichen, es ist immer vorzuziehen, das Material mit einer Fuge von 2 mm zu verlegen und Verfugungen in ähnlichen Farbtönen zu verwenden.

Pour obtenir un excellent résultat esthétique, est toujours préférable de poser le matériau avec un joint de 2 mm utilisant le Jointoiment en couleurs ton sur ton.

Для достижения наилучшего результата рекомендуется всегда стелить материал со швом в 2 мм, используя подходящую по цвету штукатурку.

# CERTIFICAZIONI DI SOSTENIBILITÀ

CERTIFICATION FOR SUSTAINABILITY / ZERTIFIZIERUNG DER NACHHALTIGKEIT / CERTIFICATIONS DE DURABILITÉ / СЕРТИФИКАТЫ СОЦИАЛЬНОЙ И ЭКОЛОГИЧЕСКОЙ ОТВЕТСТВЕННОСТИ



Il rispetto dell'ambiente, l'operare in massima sintonia con l'ambiente che ci circonda cercando di dare un serio contributo al mantenimento dell'equilibrio ambientale sono da sempre nel DNA di Ariostea. Il nostro quotidiano impegno, la nostra volontà di innovare prodotti e processi, di interpretare fedelmente le nuove sensibilità del costruire, di accogliere ed affrontare le grandi sfide del progettare ETICO e SOSTENIBILE. Ecco perché le prestigiose certificazioni di Sistema UNI EN ISO 14001, l'iscrizione al registro europeo di eco gestione Emas e le certificazioni di prodotto eco sostenibile LEED (**Leadership in Energy and Environmental Design**) & BREEAM (**Building Research Establishment Environmental Assessment Method**), sono parte integrante della politica di Ariostea.

**CERTIFICAZIONE LEED:** Già diffusa ed attiva in oltre 40 Paesi, il sistema di certificazione LEED (Leadership in Energy and Environmental Design) valuta ed attesta la sostenibilità ambientale, sociale ed economica degli edifici considerati nel loro complesso. Secondo i criteri di classificazione LEED, i materiali da costruzione con elevata ecosostenibilità contribuiscono all'ottenimento di crediti elevando il punteggio dell'edificio. Si certifica che le lastre Ariostea presentate in questo strumento contengono una percentuale di impasto riciclato (pre consumer) superiore al 40% : garantiscono quindi i più alti punteggi secondo il sistema LEED.

**CERTIFICAZIONE BREEAM:** E' tra i più diffusi standard al mondo ed è volto a misurare l'impatto ambientale degli edifici mediante l'applicazione di specifici criteri di valutazione della sostenibilità della costruzione. Il sistema di assegnazione del punteggio prevede tipologie di certificazione fissate da rigorosi parametri tecnici e di controllo qualità basati sulle più recenti tecnologie e conoscenze disponibili.

Respect for the environment and working in utmost harmony with the world around us in an effort to make a serious contribution to maintaining environmental equilibrium has always been in Ariostea's DNA. Our daily commitment, determination to innovate products and operations, to accurately interpret new trends in construction, to take on and confront the great challenges in creating Ethical and Sustainable designs are all reasons why the prestigious certifications of the UNI EN ISO 14001 System, enrolment in the European registry of Environmental Management Emas and the certification of eco-friendly products LEED (**Leadership in Energy and Environmental Design**) & BREEAM (**Building Research Establishment Environmental Assessment Method**) are an integral part of Ariostea's policy.

**LEED CERTIFICATION:** Currently widespread and used in over 40 countries, the certification system LEED (Leadership in Energy and Environmental Design) evaluates and certifies social and economic environmental sustainability of buildings considered as a whole. According to the classification criteria of LEED, building materials having a high environmental sustainability contribute to obtaining credits thus increasing the building's rating. We certify that the Ariostea tiles in question contain more than 40% (pre-consumer) recycled material: therefore they guarantee the highest LEED ratings.

**BREEAM CERTIFICATION:** It is the most widespread standard in the world and it is designed to measure the environmental impact of buildings by applying specific criteria for assessing the sustainability of the construction. The rating system requires types of certification determined by strict technical parameters and quality control which in turn are based on the most recent technology and knowledge available.

## CERTIFICAZIONI DI SISTEMA

SYSTEM CERTIFICATIONS / ZERTIFIZIERUNG / SYSTEME DE CERTIFICATIONS / СЕРТИФИКАТЫ СИСТЕМЫ КАЧЕСТВА



Certquality è membro della federazione CISQ



### SISTEMA GESTIONE QUALITÀ CERTIFICATO UNI EN ISO 9001

Certified quality system.

Qualitätssystem zertifiziert.

Système qualité certifié.

СИСТЕМА УПРАВЛЕНИЯ КАЧЕСТВОМ  
СЕРТИФИЦИРОВАНА ПО СТАНДАРТУ UNI EN  
ISO 9001.

CERT. N° 686



### GESTIONE AMBIENTALE VERIFICATA EMAS

L'iscrizione al registro EMAS (Environmental Management and Audit Scheme) testimonia l'impegno di Ariostea verso il miglioramento costante delle proprie performance ambientali.

Entry in the EMAS (Environmental Management and Audit Scheme) register is proof of Ariostea's commitment to ongoing improvement of its performances in the environment field.

Die Eintragung in das EMAS-Register (Environmental Management and Audit Scheme) ist ein Beleg für den Arbeitseinsatz der Ariostea hinsichtlich der konstanten Aufwertung ihrer Leistungen im Bereich des Umweltschutzes.

L'inscription au registre EMAS (Environmental Management and Audit Scheme) atteste l'engagement permanent d'Ariostea dans la lutte pour l'amélioration de ses performances dans le domaine de l'environnement.

СИСТЕМА УПРАВЛЕНИЯ ВОЗДЕЙСТВИЕМ НА ОКРУЖАЮЩУЮ СРЕДУ ПРОВЕРЕНА EMAS. Регистрация в реестре EMAS (Environmental Management and Audit Scheme) свидетельствует о том, что компания Ariostea взяла на себя обязательство по постоянному улучшению своих экологических показателей.

Regolamento CE n° 1221/2009 registrazione del sito produttivo di Castellarano n. IT - 000064

CE regulation n° 1221/2009 registration of Castellarano production site n. IT - 000064

Vorschrift CE n° 1221/2009 registrierung der produktionsniederlassung in Castellarano n. IT - 000064

Règlement CE n° 1221/2009 inscription du site de production de Castellarano n. IT - 000064

Распоряжение ЕС N° 1221/2009 о регистрации производственного предприятия в Кастелларано (Castellarano) за N° IT - 000064.



Certquality è membro della federazione CISQ



### SISTEMA GESTIONE AMBIENTALE CERTIFICATO UNI EN ISO 14001

Certified environmental management system.

Umweltschutzsystem zertifiziert.

Gestion environnementale certifiée.

СИСТЕМА УПРАВЛЕНИЯ ВОЗДЕЙСТВИЕМ НА  
ОКРУЖАЮЩУЮ СРЕДУ СЕРТИФИЦИРОВАНА  
ПО СТАНДАРТУ UNI EN ISO 14001.

CERT. N° 3180



Umweltfreundlichkeit, das Arbeiten im Einklang mit unserer Umwelt und das Bestreben, dabei zum Bewahren einer ausgewogenen Umwelt beizutragen, ist Ariostea seit jeher in die Wiege gelegt. Dafür setzen wir uns täglich mit dem Bestreben ein, Produkte und Produktionsprozesse stets zu erneuern, das neue Verständnis am Bau sorgsam einzusetzen und die großen Herausforderungen des ETHISCHEN und NACHHALTIGEN Bauens aufzunehmen und zu verfolgen. Deshalb sind die angesehenen Zertifizierungen des Systems UNI EN ISO 14001, der Eintrag in das europäische Register ökologischer Betriebsführung (EMAS) und die Zertifizierungen als ökonachhaltiges Produkt LEED (Leadership in Energy and Environmental Design) und BREEAM (Building Research Establishment Environmental Assessment Method) feste Bestandteile der Firmenpolitik von Ariostea.

**LEED-ZERTIFIZIERUNGEN:** Das bereits in mehr als 40 Ländern präsente und aktive Zertifizierungssystem LEED (Leadership in Energy and Environmental Design) prüft und bestätigt die umweltfreundliche, soziale und ökonomische Nachhaltigkeit der Bauten in ihrer Gesamtheit. Den Klassifizierungskriterien von LEED entsprechend tragen hochrangig ökonachhaltige Baumaterialien dazu bei, Pluspunkte für das Gebäude zu sammeln. Es wird bestätigt, dass die in diesem Instrument vorgelegten Ariostea-Platten einen Prozentsatz von mehr als 40 % an wiederverwerteter Mischung (pre-consumer) enthalten: Sie gewährleisten also nach dem LEED-System die höchsten Punktezahlen.

**BREEAM-ZERTIFIZIERUNG:** Sie gehört zu den weltweit am meisten verbreiteten Standards und dient dazu, die Umweltbelastung der Gebäude mit speziellen Beurteilungskriterien der Nachhaltigkeit des Baus zu bemessen. Die Zuerkennung der Punktebewertung sieht Zertifizierungen vor, die nach strengen, auf den neuesten Technologien und Erkenntnissen aufbauenden Maßstäben von Technik und Qualitätskontrolle festgelegt sind.

Le respect de l'environnement, l'intervention en totale harmonie avec l'environnement qui nous entoure, la recherche d'une contribution sérieuse au maintien de l'équilibre environnemental sont depuis toujours inscrits dans l'ADN d'Ariostea. Notre engagement quotidien, notre volonté d'innover en matière de produits et de processus, d'interpréter fidèlement les nouvelles sensibilités du bâtiment, d'accueillir et de relever les grands défis de la conception ÉTHIQUE et DURABLE. C'est la raison pour laquelle les prestigieuses certifications de Système UNI EN ISO 14001, l'inscription au registre européen d'écogestion Emas et les certifications de produit écosoutenable LEED (Leadership in Energy and Environmental Design) & BREEAM (Building Research Establishment Environmental Assessment Method), font partie intégrante de la politique d'Ariostea.

**CERTIFICATION LEED:** Déjà présent et actif dans plus de 40 Pays, le système de certification LEED (Leadership in Energy and Environmental Design) évalue et certifie la compatibilité environnementale, sociale et économique des bâtiments dans leur ensemble. Conformément aux critères de classification LEED, les matériaux de construction à éco-durabilité élevée favorisent l'obtention de crédits en faisant monter la cote du bâtiment. Les plaques carrelages Ariostea présentées dans ce document contiennent un pourcentage de gâchage recyclé (pré-consommateur) de plus de 40 %: elles obtiennent donc les scores les plus élevés selon le système LEED.

**CERTIFICATION BREEAM:** C'est l'une des normes les plus répandues au monde et elle permet de mesurer l'impact environnemental des bâtiments selon des critères précis d'évaluation de la durabilité de la construction. Le système d'attribution du score prévoit des types de certification établis selon des paramètres techniques rigoureux et des contrôles qualité basés sur technologies et les connaissances disponibles les plus récentes.

Охрана окружающей среды, существование в гармонии с природой, которая нас окружает, стремление внести значительный вклад в поддержание природного равновесия — всё это является ключевыми аспектами деятельности компании Ariostea. Все наши желания и усилия направлены на инновацию продуктов и рабочих процессов, на следование последним веяниям, выраженное в том, чтобы определить и принять программу СОЦИАЛЬНОЙ и ЭКОЛОГИЧЕСКОЙ ОТВЕТСТВЕННОСТИ, а также понять ее наиболее важные задачи. Именно поэтому такие признанные сертификаты как UNI EN ISO 14001, регистрация в европейском реестре управления воздействием на экологию EMAS, и паспорт изделия на соответствие параметрам политики экологической ответственности LEED (Leadership in Energy and Environmental Design), а также BREEAM (Building Research Establishment Environmental Assessment Method) являются неотъемлемой частью политики компании Ariostea.

**СЕРТИФИКАЦИЯ LEED** (Leadership in Energy and Environmental Design) распространена более чем в сорока странах. Система сертификации LEED (Лидерство в проектировании с учетом аспектов энергосбережения и экологии) оценивает и подтверждает, что здание в целом было построено с учетом аспектов ответственности за экологическую, социальную и экономическую сферу. Согласно критериям сертификации LEED, строительные материалы, созданные с учетом экологической ответственности, помогают завоевать доверие на рынке и повысить привлекательность здания с точки зрения его оценки. Доказано, что плитка, содержащая более 40% материалов, подлежащих повторному использованию, обеспечивает продукту самые высокие оценки по системе LEED.

**СЕРТИФИКАЦИЯ BREEAM.** Это один из самых распространенных мировых стандартов, который используется для оценки влияния зданий на окружающую среду, путем применения специальных критериев по аспекту экологической ответственности. Система начисления баллов предусматривает несколько типов сертификатов на основании жестких технических параметров, а также контроля качества, опирающегося на последние разработки и существующие знания в данной области.

## CERTIFICAZIONI DI PRODOTTO

PRODUCT CERTIFICATIONS / PRODUKTPRÜFBERICHTE / CERTIFICATIONS DE PRODUIT / СЕРТИФИКАТЫ НА ИЗДЕЛИЕ

ITALY

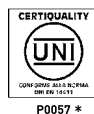

U.S.A.



American Society for Testing and Materials

FRANCE



Centre Scientifique Technique du Batiment France: Classement U.P.E.C. Agréé\*\*

UKRAINE



RUSSIA



State Sanitary-Epidemic Department of Russian Federation

### CERTIFICAZIONI DI PRODOTTO

Certificazioni rilasciate per i materiali Ariostea dai seguenti organismi ufficiali.

#### Product certifications

Certifications issued for Ariostea materials by the following official bodies.

#### Produktprüfberichte

Diese prüfberichte sind für die materialien Ariostea von den folgenden öffentlichen behörden ausgestellt worden.

#### Certifications de produit

Certifications délivrées pour les matériaux Ariostea par les organismes officiels suivants.

#### СЕРТИФИКАТЫ НА ИЗДЕЛИЕ

Сертификаты на материалы компании Ariostea выданы следующими официальными органами.

\* La lista dei prodotti Ariostea certificati Certquality/UNI è disponibile sul sito internet [www.ariostea.it](http://www.ariostea.it)

\*\* La liste à jour des matériaux Ariostea certifiés UPEC est disponible sur le site internet [www.cstb.fr](http://www.cstb.fr).



## ARIOSTEA HEADQUARTER

Castellarano, Reggio Emilia - Italy  
[www.ariosteia.it](http://www.ariosteia.it)  
[info@ariosteia.it](mailto:info@ariosteia.it)

**Numero Verde**  
800-214252